

FABER COLLECTION
COLECCIÓN FABER

FABER

 **FABER**
AIR MATTERS

SMART LIFE - SMART TECHNOLOGY

Always striving to provide innovative solutions to improve life, Faber has conceived its hoods as a new way of using, designing - and why not, of experiencing - the kitchen.

The objective is to offer new technological products that improve air quality, thinking outside the box and in line with the latest demands.

Concrete and practical with present needs, updated with the latest technology and design, attentive to the quality of the product, consumption and the environment. Curious about changes in lifestyle. Visionary on the future.

This is the Faber spirit.

Siempre en búsqueda de generar soluciones para un mejor estilo de vida, Faber ha concebido sus campanas como una nueva forma de uso, diseño y, por qué no, de vivir una experiencia en la cocina.

El objetivo es ofrecer productos con nueva tecnología que mejoren la calidad de aire pensando "fuera de la caja" y en línea de las nuevas demandas.

Concreto y práctico con el presente y sus necesidades, actualizados con la nueva tecnología y diseño, sin descuidar la calidad del producto, el consumo y el ambiente, interesado en los cambios en el estilo de vida: visionarios del futuro.

Este es el espíritu Faber.

THE GREENEST BRAND



LA MARCA MÁS VERDE

BUYING A GREEN HOOD INSTEAD OF A STANDARD ONE WILL AVOID THE EMISSION OF 288 KG. OF CO2 PER YEAR

COMPRAR UNA CAMPANA «VERDE» EN VEZ DE UNA CAMPANA ESTÁNDAR EVITARÁ LA EMISIÓN DE 288 KG DE CO2 AL AÑO.

WHICH IS EQUAL TO DRIVING 1.747 KM. LESS EVERY YEAR!

QUE EQUIVALE A MANEJAR 1.747 KM MENOS EN UN AÑO!



LED light creates powerful cutting-edge lighting by combining excellent light distribution in the cooking area with a pleasant and relaxing intensity (4100 °K), with a low level of energy consumption, just 2W.

La luz LED asegura la potencia necesaria de iluminación de última generación, combinando una óptima distribución de la luz dentro del área de la cocina con una luz placentera y relajante (4100K) y un consumo de energía de sólo 2W.

The performance shown in this catalogue is declared in accordance with the new Code of Conduct signed by the most qualified European manufacturers members of CECED (European Committee of Domestic Equipment Manufacturers), a strict code for transparency which establishes clear rules to measure air flow and noise level for hoods, common to all cooker hoods manufacturers:

- Air capacity according to IEC/EN 61591 method (with the hood fitted using a ducting pipe)
- Noise level according to IEC/EN 60704-3 method (sound power)

El rendimiento presentado en este catálogo está basado en el nuevo Código de Conducta firmado por los fabricantes más calificados que son miembros del Comité Europeo de Fabricantes Nacionales de Equipos (CECED, por sus siglas en inglés). Este código de transparencia estricta establece reglas claras para medir el flujo de aire y el nivel de ruido de las campanas de cocina que le son comunes a todos los fabricantes de dichos equipos:

- Capacidad de succión de acuerdo a la normativa IEC/EN 61591 (con la campana instalada usando un ducto de extracción)
- Nivel de ruido de acuerdo a la normativa IEC/EN 60704-3 (potencia sonora)

PERFORMANCE / RENDIMIENTO

| | |
|------------------------|---|
| SPEED | Speed / Velocidad |
| M³/H | Air capacity IEC point / Capacidad de succión punto IEC |
| PA | Pressure / Presión |
| W | Input / Potencia |
| dB(A) | Noise level / Nivel de ruido |

TECHNOLOGICAL PLUS / PLUS TECNOLÓGICO



HFH: EXCLUSIVE HIGH FILTERING SYSTEM EFFECTIVENESS

HFH: SISTEMA DE FILTRADO EXCLUSIVO DE ALTA EFICIENCIA

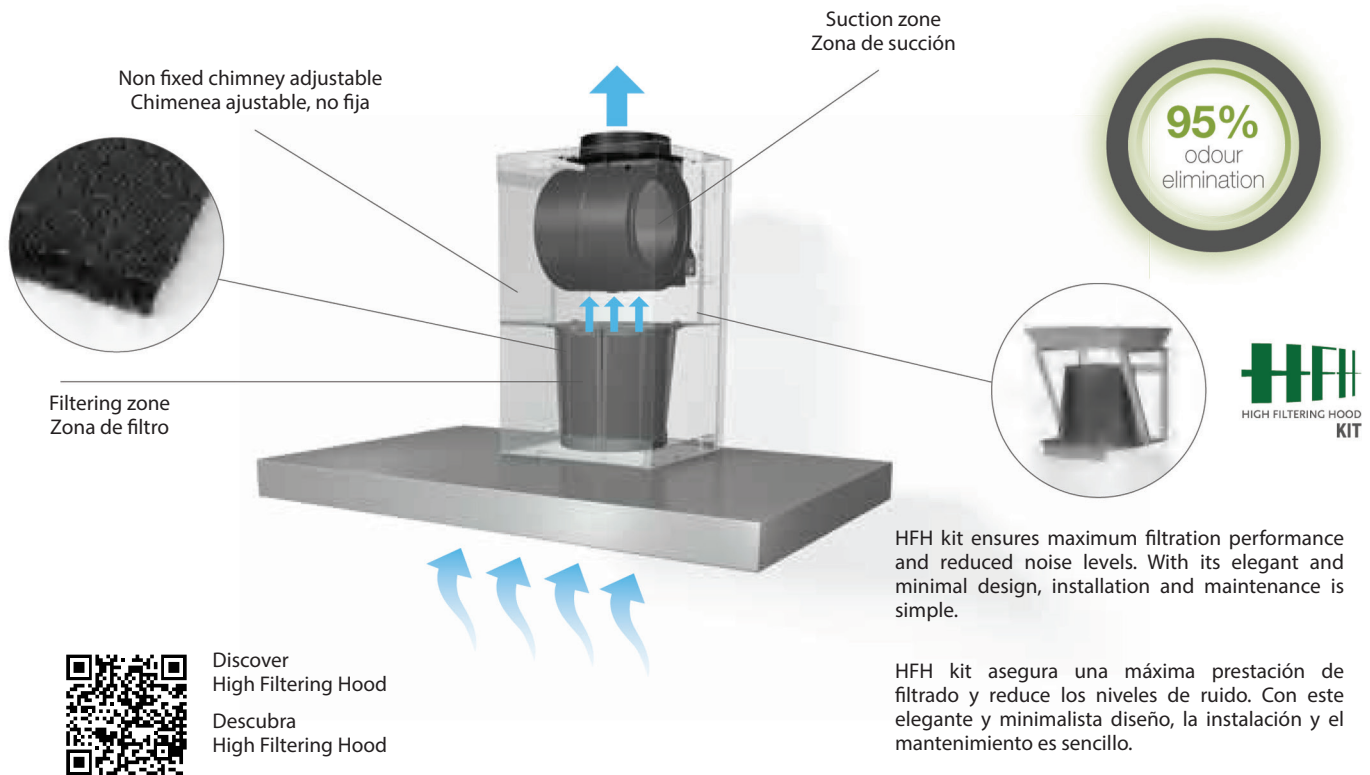

HFH is a highly effective, exclusive Faber active carbon filtering system. When compared to traditional flat-shaped filters, the cylindrical filter allows for having a broad surface to enhance the air flow. Even the filtering material has an exclusive concept, in that it comprises of two panels with different porosity and active carbon concentration. The first layer processes the larger particles and facilitates the task of the second panel, which intervenes on the smaller particles as well. Maintenance is highly straightforward: the cylindrical shape allows for easy removal of the filtering material which can then be washed in the dishwasher. HFH guarantees a noise reduction of around 3 dB(A) compared to traditional active carbon filters.

HFH es un sistema de filtro de carbón activado muy efectivo, exclusivo de Faber. Cuando comparamos al tradicional filtro plano, el filtro cilíndrico genera mayor poder de filtrado debido a una superficie general que facilita el flujo de aire. De esta forma, las partículas olorizadas se encuentran en contacto con las partículas de carbón activado por más tiempo y con mayor facilidad. El material filtrante tiene un exclusivo concepto, se comprimieron dos paneles con diferentes porosidades y diferentes concentraciones de carbón. La primera capa procesa las partículas grandes y facilita la tarea del segundo panel, el cual atrapa las partículas pequeñas. Mantenimiento sencillo: la forma cilíndrica nos permite remover fácilmente el material filtrante el cual puede ser lavado en la lavavajillas. HFH garantiza una reducción de ruido de alrededor de 3 dB(A) en comparación con el sistema tradicional de filtros de carbón.

F-LIGHT GENERATION: HOOD AND LIGHT

GENERACIÓN F-LIGHT: CAMPANA E ILUMINACIÓN



HOOD

Up & Down technology offers maximum comfort and practicality in the kitchen: operated by remote control the hood gently lowers onto the hob increasing its efficiency.

When the hood is no longer needed, it rises towards the ceiling with a simple press of a button, freeing the space surrounding the burners.

CAMPANA

La tecnología Up & Down ofrece un confort máximo y practicidad en la cocina, operada por control remoto la campana desciende suavemente hasta la zona de cocción incrementando su eficiencia.

Cuando la campana no se necesita más, vuelve a elevarse a nivel de techo con un simple toque de botón liberando el espacio cercano a los quemadores.



LIGHT

All F-LIGHT Generation hoods are state-of-the-art and turn the hood into a fully-fledged lighting system, inspired by the latest trends in lighting design.

ILUMINACIÓN

Todos los extractores de la generación F-LIGHT cuentan con tecnología de punta y convierten a la campana en un sistema completo de iluminación, inspirado en las últimas tendencias de diseño.

Faber technological plus

El plus tecnológico de Faber

TECHNOLOGY THAT **ENABLES ENERGY SAVING**

TECNOLOGÍA QUE **PERMITE UN AHORRO DE ENERGÍA**



LED light – Creates powerful cutting-edge lighting by combining excellent light distribution in the cooking area with a pleasant and relaxing intensity (4100 °K), with a low level of energy consumption, just 2W.

Luz LED – Crea una potente iluminación de vanguardia combinando una excelente distribución lumínica en el área de cocción con una relajante y confortable luz (4100K), con un bajo nivel de consumo energético, tan solo de 2W).

TECHNOLOGY THAT MAKES FABER HOODS **QUIETER**

LA TECNOLOGÍA QUE PERMITE QUE LAS CAMPANAS FABER **SEAN SILENCIOSAS**



Comfort Panel – Reduces the perceived sound by 25%.
Highly-developed perimeter aspiration that guarantees optimised effectiveness exploiting the principle of the Venturi effect: air accelerates as it passes through the constricted extraction space of the panel and then decreases immediately inside the hood and is then easily expelled without need for any particular pressure.

Panel Confort – Reduce el sonido percibido en un 25%.
Aspiración perimetral de alto desarrollo que garantiza una efectividad óptima haciendo uso del principio de Venturi: el aire se acelera al pasar por el espacio reducido de extracción del panel y desacelera inmediatamente dentro de la campana y es fácilmente expulsado sin necesidad de una presión particular.

Faber technological plus

El plus tecnológico de Faber

SPEED

Intensive speed – Function which activates maximum aspiration for 6 minutes to meet special cooking needs.

Velocidad intensiva – Activa la máxima aspiración por 6 minutos para hacer frente a exigencias particulares.

DELAY 30'

Delayed switch-off – Allows automatic delayed switching off of the motor to complete elimination of residual odours.

Apagado programado – Permite el apagado automático del motor para completar la eliminación de los olores residuales.

HOUR

Key 24 – Function which allows the hood to be switched on for 24 hours a day for continuous air renewal with a level of noise that is imperceptible.

Key 24 – Función que permite mantener la campana encendida 24 horas al día renovando el aire con un nivel de ruido imperceptible.

FILTER ALARM

Filter saturation alarm – Warns you when it is time to clean the grease filter or substitute the anti-odour filter.

Alarma de saturación de filtro – Señala cuando es el momento de limpiar el filtro antigrasa o sustituir el filtro antiolores.

REMOTE CONTROL

Remote control – Faber hoods with electronic commands come with remote controls, which are particularly useful for people with reduced mobility.

Control remoto – Las campanas Faber con controles electrónicos vienen acompañadas de control remoto, lo que es particularmente útil para personas con limitaciones motoras.

DIMMER LIGHT

Dimmer light – Adjusts hood courtesy light with the simple press of a button to meet all your kitchen needs.

Luz tenue – Ajusta la luz de cortesía de la campana tan sólo con presionar un botón.

MOTORS THAT MAKE FABER HOODS MORE EFFICIENT

MOTORES QUE HACEN DE LAS CAMPANAS FABER UN PRODUCTO MÁS EFICIENTE

ENERGY

Energy diffuser – Reduces noise up to 3dB(A) and higher hood efficiency by 30% even in the presence of long air outlet.

Difusor de energía – Reduce el ruido hasta 3dB(A) y mayor eficiencia de un 30% aun en presencia de salidas lejanas de aire.

WALL HOOD

CAMPANAS DE PARED

The form and precious materials of our wall hood designs have been carefully studied to be visually pleasant and to last over time. They utilise powerful motorisation and refined aspiration systems to guarantee clean air and silence.

Our hoods provide useful special functions for a clean environment, to keep your home under control, to leave you free to manage creativity in your kitchen.

La forma y los materiales de nuestras campanas de pared han sido cuidadosamente estudiados para generar placer a la vista. Estas utilizan motores potentes, refinados sistemas de aspiración para garantizar limpieza y silencio. Nuestras campanas proveen funciones especiales para limpiar el ambiente, para mantener su casa bajo control y para dejarle total creatividad para formar la cocina.





Cocktail

WALL HOOD CAMPANA DE PARED

- COCKTAIL BK F80 cod. 110.0298.935
- COCKTAIL WH F80 cod. 110.0298.936

110-127V 60Hz



NEW TECHNOLOGY
NUEVA TECNOLOGÍA



Discover ENERGY SAVING
and other technologies
Descubra ENERGY SAVING
y otras tecnologías

| | |
|--|--|
| Finish Acabado | Black glass - White glass Vidrio negro - Vidrio blanco |
| Controls Controles | Touch control Control táctil |
| Lighting (Included) Iluminación (Incluida) | 2 halogen lights 2 bombillos halógenos |
| Grease filter Filtro antigrasa | Filters dishwasher safe Filtros lavables |
| Ø of air outlet Salida de aire | 150 / 120 mm. |
| Width Ancho | 800 mm. |
| Energy class Clase de energía | C |



| | | | | |
|---|-----|-----|-----|-----|
| Speed Velocidad | 1 | 2 | 3 | INT |
| Air capacity M3H Capacidad de succión | 250 | 370 | 475 | 530 |
| Air capacity CFM Capacidad de succión | 147 | 217 | 279 | 311 |
| Pressure Presión | 190 | 265 | 280 | 290 |
| Input Potencia | 90 | 105 | 125 | 140 |
| Noise level Nivel de ruido | 49 | 57 | 63 | 66 |

Included accessories / Accesorios incluidos

- cod. 112.0157.240 **Charcoal filter**
Filtro de carbón activado

Optional accessories / Accesorios opcionales

- cod. 112.0250.289 **Chimney kit X**
Kit de chimenea superior X
- cod. 112.0250.290 **Chimney kit BK**
Kit de chimenea BK
- cod. 112.0158.127 **Charcoal filter High Performance**
Filtro de carbón activado de alto desempeño

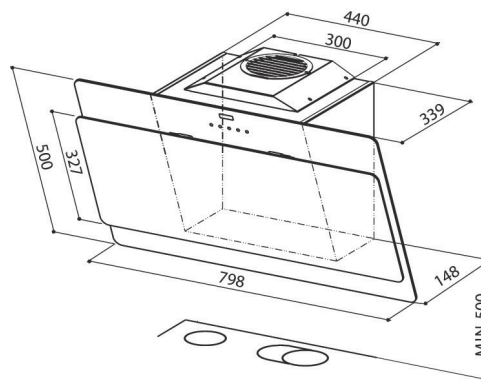

To be installed at a minimum distance
from the hob of 50 cm.

Para ser instalada a una distancia mínima
del área de cocción de 50 cm.

Stilo

WALL HOOD CAMPANA DE PARED

• STILO XF90 cod. 110.0195.002

110-127V 60Hz



| | |
|--|--|
| Finish Acabado | Stainless steel Acero inoxidable |
| Controls Controles | Electronic Electrónicos |
| Lighting (Included) Iluminación (Incluida) | Halogen lamps 2x28W Bombillos halógenos 2x28 W |
| Grease filter Filtro antigrasa | Filters dishwasher safe Filtros lavables |
| Ø of air outlet Salida de aire | 120 mm. |
| Width Ancho | 900 mm. |
| Energy class Clase de energía | E |



NEW TECHNOLOGY NUEVA TECNOLOGÍA



Discover ENERGY SAVING
and other technologies

Descubra ENERGY SAVING
y otras tecnologías

| Speed Velocidad | 1 | 2 | 3 | 4 |
|---|-----|-----|-----|-----|
| Air capacity M3H Capacidad de succión | 310 | 480 | 610 | 685 |
| Air capacity CFM Capacidad de succión | 182 | 282 | 359 | 403 |
| Pressure Presión | 370 | 460 | 480 | 500 |
| Input Potencia | 135 | 170 | 215 | 250 |
| Noise level Nivel de ruido | 54 | 62 | 66 | 70 |

Included accessories / Accesorios incluidos

- cod. 112.0157.243 **Charcoal filter**
Filtro de carbón activado

Optional accessories / Accesorios opcionales

- cod. 112.0157.271 **Backsplash X 900 mm.**
Backsplash X 900 mm.
- cod. 112.0157.252 **Upper chimney kit X**
Kit superior de chimenea X
- cod. 112.0327.631 **HFH filter kit**
Kit de filtro HFH

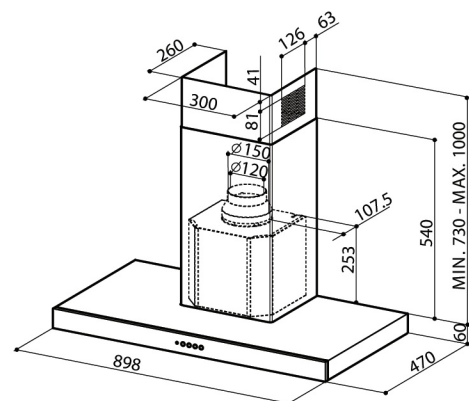

ISLAND HOOD

CAMPANAS DE ISLA

Perfect in their every detail, extremely powerful, ideal for all-round kitchen use.

Island workstation kitchens take on a central role in the house and in daily family life: cooking instantly develops into personal flair, passion, choice, an intimate, private activity. Island decorative hoods are attractive from all viewpoints, with perfect form in all its features: there is no hidden side or corner not seen by the naked eye. Characterised by symmetry and uniformity, illuminating the centre of our family lives.

Perfectas en todo detalle, extremadamente poderosas, ideales para el uso completo de la cocina. Las cocinas con estación de trabajo en isla toman un rol central en la casa y en el día a día de las familias: el cocinar, instantáneamente, desarrolla un ambiente personal, pasión, elección, una íntima y privada actividad. Las campanas de isla son atractivas desde todos los puntos de vista, con formas perfectas no hay ningún lado o rincón escondido que quede oculto a simple vista. Caracterizada por simetría y uniformidad, iluminación al centro de nuestra vida familiar.



FABER

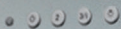

Stilo Isola

ISLAND HOOD
CAMPANA DE ISLA

- STILO ISOLA X F90 cod. 110.0195.073
- STILO ISOLA X F120 cod. 110.0195.074

110-127V 60Hz



Finish
Acabado

Stainless steel
Acero inoxidable

Controls
Controles

Electronic
Electrónicos

Lighting (Included)
Iluminación (Incluida)

4 LED lights
4 luces LED

Grease filter
Filtro antigrasa

Filters dishwasher safe
Filtros lavables

Ø of air outlet
Salida de aire

150 / 120 mm.

Width
Ancho

900 / 1200 mm.

Energy class
Clase de energía

C



NEW TECHNOLOGY
NUEVA TECNOLOGÍA



Discover ENERGY SAVING
and other technologies

Descubra ENERGY SAVING
y otras tecnologías

| Speed Velocidad | 1 | 2 | 3 | INT |
|---|-----|-----|-----|-----|
| Air capacity M3H Capacidad de succión | 315 | 480 | 610 | 685 |
| Air capacity CFM Capacidad de succión | 185 | 282 | 359 | 403 |
| Pressure Presión | 370 | 460 | 480 | 500 |
| Input Potencia | 135 | 170 | 215 | 250 |
| Noise level Nivel de ruido | 54 | 62 | 67 | 70 |

Included accessories / Accesorios incluidos

- cod. 112.0157.243

Charcoal filter
Filtro de carbón activado

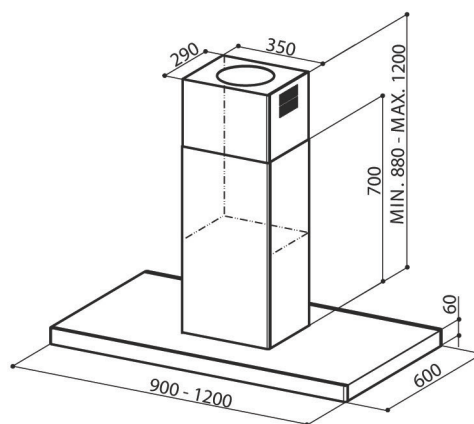

Glassy Isola

ISLAND HOOD
CAMPANA DE ISLA

• GLASSY ISOLA EG8 X/V F90 cod. 110.0183.861

110-127V 60Hz

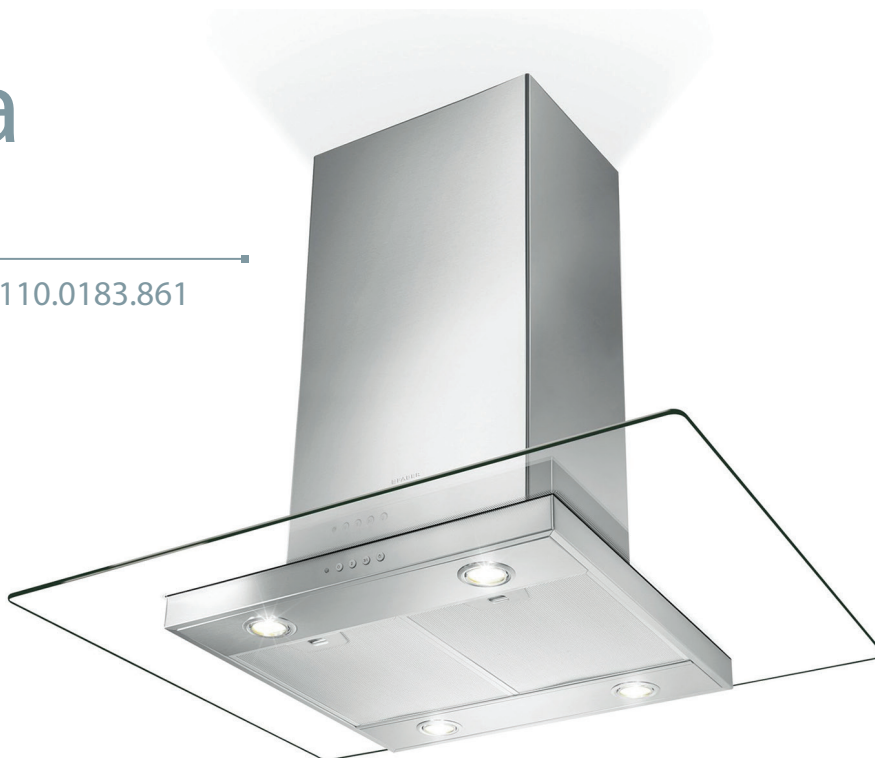

Finish
Acabado

Stainless steel
Acero inoxidable

Controls
Controles

Electronic
Electrónicos

Lighting (Included)
Iluminación (Incluida)

4 halogen lights
4 bombillos halógenos

Grease filter
Filtro antigrasa

Filters dishwasher safe
Filtros lavables

Ø of air outlet
Salida de aire

150 / 120 mm.

Width
Ancho

900 mm.

Energy class
Clase de energía

C



NEW TECHNOLOGY
NUEVA TECNOLOGÍA



Discover ENERGY SAVING
and other technologies

Descubra ENERGY SAVING
y otras tecnologías

| Speed Velocidad | 1 | 2 | 3 | INT |
|---|-----|-----|-----|-----|
| Air capacity M3H Capacidad de succión | 255 | 395 | 540 | 650 |
| Air capacity CFM Capacidad de succión | 150 | 232 | 317 | 382 |
| Pressure Presión | 360 | 450 | 480 | 500 |
| Input Potencia | 135 | 170 | 215 | 250 |
| Noise level Nivel de ruido | 45 | 56 | 63 | 69 |

Included accessories / Accesorios incluidos

- cod. 112.0157.243

Charcoal filter
Filtro de carbón activado

Optional accessories / Accesorios opcionales

- cod. 112.0157.288

1 baffle filter kit X (order 2 kits)
1 kit de filtro antigrasa X (2 kits)

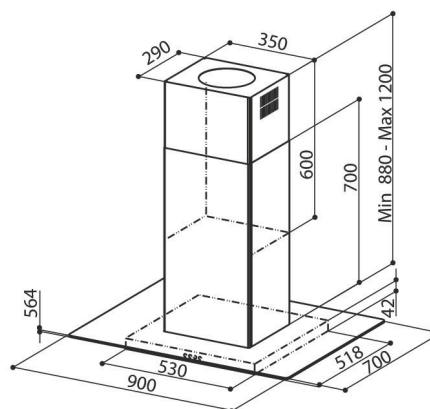



Cylindra Isola

ISLAND HOOD
CAMPANA DE ISLA

• CYLINDRA ISOLA F37 ELN cod. 110.0194.569

110-127V 60Hz

| | |
|--|---|
| Finish Acabado | Stainless steel - White Acero inoxidable - Blanco |
| Controls Controles | Electronic Electrónicos |
| Lighting (Included) Iluminación (Incluida) | Halogen spotlights 4x20W Focos halógenos 4x20W |
| Grease filter Filtro antigrasa | Filters dishwasher safe Filtros lavables |
| Ø of air outlet Salida de aire | 150 / 120 mm. |
| Width Ancho | 370 mm. |
| Energy class Clase de energía | D |



Opcional



| | | | | |
|---|-----|-----|-----|-----|
| Speed Velocidad | 1 | 2 | 3 | INT |
| Air capacity M3H Capacidad de succión | 250 | 390 | 540 | 590 |
| Air capacity CFM Capacidad de succión | 147 | 229 | 317 | 347 |
| Pressure Presión | 360 | 450 | 480 | 500 |
| Input Potencia | 135 | 170 | 215 | 250 |
| Noise level Nivel de ruido | 47 | 57 | 63 | 67 |

Included accessories / Accesorios incluidos

- cod. 112.0157.243 **Charcoal filter**
Filtro de carbón activado

Optional accessories / Accesorios opcionales

- cod. 112.0157.354 **Remote control**
Control remoto

- cod. 112.0157.267 **Upper chimney kit X**
Kit de chimenea superior X

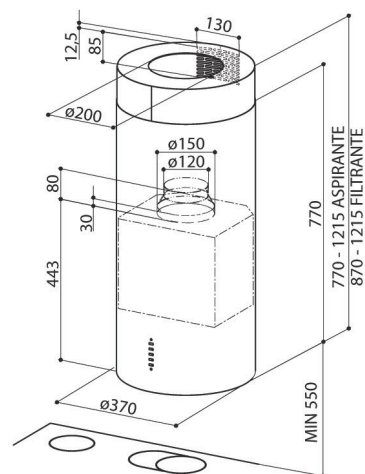

F-LIGHT GENERATION

GENERACIÓN F-LIGHT

The F-LIGHT cooker hoods were created to represent the perfect integration of design and wellbeing. The design is absolutely extraordinary and astounds the observer due to its ability to revolutionise the concept of cooker hood lighting, transforming it into a real point of light for the kitchen area. The products are technologically advanced and perfectly shaped, offering the user freedom of movement within the cooking zone. In a simple movement, elegance becomes functionality.

Las campanas F-LIGHT fueron creadas para representar la perfecta integración de diseño y beneficio. El diseño es absolutamente extraordinario e impacta a los observadores, debido a su capacidad de transformarse en un verdadero punto de luz dentro de la cocina. Los productos son tecnológicamente muy avanzados y perfectamente fabricados, ofreciendo al usuario libertad de movimiento en la zona de cocción. En un sólo movimiento, la elegancia se convierte en funcionalidad.

FABER



Kaleidos

ISLAND HOOD UP & DOWN
CAMPANA DE ISLA UP & DOWN

• KALEIDOS cod. 110.0157.237

220-240V 50-60Hz

NEW TECHNOLOGY
NUEVA TECNOLOGÍA



Discover ENERGY SAVING
and other technologies

Descubra ENERGY SAVING
y otras tecnologías



| | |
|--|--|
| Finish Acabado | Stainless steel - Fabric Acero inoxidable - Fibra textil |
| Controls Controles | Electronic Electrónicos |
| Lighting (Included) Iluminación (Incluida) | 4 halogen lights 4 bombillos halógenos |
| Grease filter Filtro antigrasa | Filters dishwasher safe Filtros lavables |
| Ø of air outlet Salida de aire | 150 mm. |
| Width Ancho | 600 mm. |
| Energy class Clase de energía | C |

F-LIGHT cooker hoods were designed to offer maximum flexibility and to adapt to any domestic environment.

Each model should therefore be purchased with the relevant accessories in order to create the desired version:

- Hose for installation as a ducted appliance
- FABER lighting kit. If you would prefer to use a different type of lighting, please contact an authorised lighting accessories dealer

Las campanas para cocina F-LIGHT han sido diseñadas para ofrecer la máxima versatilidad y adaptarse a cualquier ambiente doméstico. Cada modelo debe ser comprado con los accesorios necesarios, con el objetivo de crear la versión deseada:

- Manguera para su instalación como aparato en un ducto
- Kit de luces FABER. Si usted prefiere usar diferentes tipos de focos, favor de contactar a su distribuidor autorizado de los accesorios de iluminación locales



| | | | | |
|---|-----|-----|-----|-----|
| Speed Velocidad | 1 | 2 | 3 | INT |
| Air capacity M3H Capacidad de succión | 230 | 345 | 450 | 520 |
| Air capacity CFM Capacidad de succión | 135 | 203 | 264 | 306 |
| Pressure Presión | 360 | 450 | 480 | 500 |
| Input Potencia | 135 | 170 | 215 | 250 |
| Noise level Nivel de ruido | 49 | 60 | 65 | 68 |

Included accessories / Accesorios incluidos

- cod. 112.0158.127 **Charcoal filter High Performance**
Filtro de carbón activado de alto desempeño
- cod. 112.0157.354 **Remote control**
Control remoto

Optional accessories / Accesorios opcionales

- cod. 112.0169.137 **6 LED lights kit**
Kit de 6 luces LED

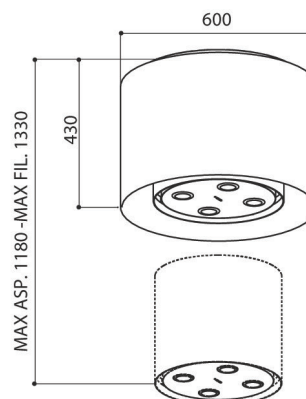



Vanilla

ISLAND HOOD UP & DOWN CAMPANA DE ISLA UP & DOWN

• VANILLA cod. 110.0157.149

220-240V 50-60Hz

NEW TECHNOLOGY
NUEVA TECNOLOGÍA



Discover ENERGY SAVING
and other technologies

Descubra ENERGY SAVING
y otras tecnologías



| | |
|--|---|
| Finish Acabado | Stainless steel - Glass Acero inoxidable - Vidrio |
| Controls Controles | Electronic Electrónicos |
| Lighting (Included) Iluminación (Incluida) | 4 halogen lights 4 bombillos halógenos |
| Grease filter Filtro antigrasa | Filters dishwasher safe Filtros lavables |
| Ø of air outlet Salida de aire | 150 mm. |
| Width Ancho | 520 mm. |
| Energy class Clase de energía | C |

F-LIGHT cooker hoods were designed to offer maximum flexibility and to adapt to any domestic environment.

Each model should therefore be purchased with the relevant accessories in order to create the desired version:

- Hose for installation as a ducted appliance
- FABER lighting kit. If you would prefer to use a different type of lighting, please contact an authorised lighting accessories dealer

Las campanas para cocina F-LIGHT han sido diseñadas para ofrecer la máxima versatilidad y adaptarse a cualquier ambiente doméstico.

Cada modelo debe ser comprado con los accesorios necesarios, con el objetivo de crear la versión deseada:

- Manguera para su instalación como aparato en un ducto
- Kit de luces FABER. Si usted prefiere usar diferentes tipos de focos, favor de contactar a su distribuidor autorizado de los accesorios de iluminación locales



| | | | | |
|---|-----|-----|-----|-----|
| Speed Velocidad | 1 | 2 | 3 | INT |
| Air capacity M3H Capacidad de succión | 230 | 345 | 450 | 520 |
| Air capacity CFM Capacidad de succión | 135 | 203 | 264 | 306 |
| Pressure Presión | 360 | 450 | 480 | 500 |
| Input Potencia | 135 | 170 | 215 | 250 |
| Noise level Nivel de ruido | 49 | 60 | 65 | 68 |

Included accessories / Accesorios incluidos

| | |
|---------------------|--|
| - cod. 112.0158.127 | Charcoal filter High Performance Filtro de carbón activado de alto desempeño |
| - cod. 112.0157.354 | Remote control Control remoto |

Optional accessories / Accesorios opcionales

| | |
|---------------------|---|
| - cod. 112.0169.137 | 6 LED lights kit Kit de 6 luces LED |
|---------------------|---|

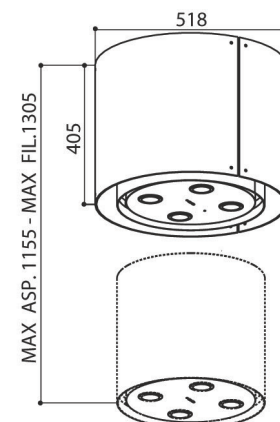



BUILT-IN DESIGN

DISEÑO BUILT-IN

Progress is expressed in the extremely clear-cut design of a perfect hideaway structure. The innovative, minimal look makes this model hood with ceiling installation a design item that hides high performance thanks to the perimeter suction technology employed.

The perfect balance of function and form, where technology does its utmost to ensure comfort and practicality, with a discreet presence in the kitchen.

El progreso se expresa en diseño con cortes claros y con estructuras perfectamente ocultas. La innovación y el look minimalista hacen que estos modelos con instalación al techo puedan ocultar un alto desempeño en su interior con una nueva tecnología de aspiración perimetral.

El balance perfecto entre formas y succión, donde la tecnología hace su mejor esfuerzo con una presencia discreta en la cocina.



Heaven Glass 2.0

DESIGNER BUILT-IN HOOD
CAMPANA DE DISEÑO BUILT-IN

• HEAVEN GLASS 2.0 WH A90 cod. 110.0315.503

220-240V 50-60Hz



NEW TECHNOLOGY
NUEVA TECNOLOGÍA



Discover ENERGY SAVING
and other technologies
Descubra ENERGY SAVING
y otras tecnologías

Finish
Acabado

White glass
Vidrio blanco

Controls
Controles

Electronic LED
Electrónicos LED

Lighting (Included)
Iluminación (Incluida)

2 LED lights
2 luces LED

Grease filter
Filtro antigrasa

Filters dishwasher safe
Filtros lavables

Ø of air outlet
Salida de aire

150 mm.

Width
Ancho

900 mm.

Energy class
Clase de energía

C



| Speed Velocidad | 1 | 2 | 3 | INT |
|---|-----|-----|-----|-----|
| Air capacity M3H Capacidad de succión | 360 | 545 | 640 | 740 |
| Air capacity CFM Capacidad de succión | 211 | 320 | 376 | 435 |
| Pressure Presión | 380 | 440 | 480 | 500 |
| Input Potencia | 140 | 185 | 250 | 275 |
| Noise level Nivel de ruido | 54 | 64 | 68 | 71 |

Included accessories / Accesorios incluidos

- cod. 112.0157.354 **Remote control**
Control remoto

Optional accessories / Accesorios opcionales

- cod. 112.0157.240 **Charcoal filter**
Filtro de carbón activado

-- cod. 112.0158.127 **Charcoal filter High Performance**
Filtro de carbón de alto rendimiento

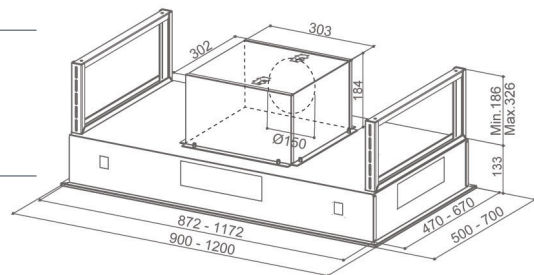

Outlet of air adjustable in 4 positions
Salida de aire ajustable en 4 posiciones



SkyLift

DESIGNER BUILT-IN HOOD
CAMPANA DE DISEÑO BUILT-IN

• SKYLIFT cod. 110.0324.939

220-240V 50-60Hz

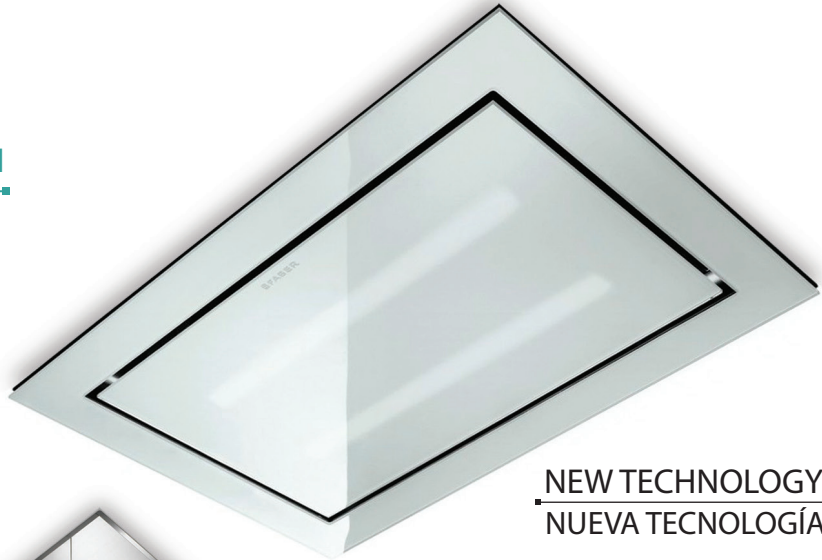

NEW TECHNOLOGY
NUEVA TECNOLOGÍA



Discover ENERGY SAVING
and other technologies
Descubra ENERGY SAVING
y otras tecnologías



Discover SkyLift
Descubra SkyLift

Finish
Acabado

Stainless steel / White glass
Acero inoxidable / Vidrio blanco

Controls
Controles

Electronic
Electrónicos

Lighting (Included)
Iluminación (Incluida)

2 LED lights
2 luces LED

Grease filter
Filtro antigrasa

Filters dishwasher safe
Filtros lavables

Ø of air outlet
Salida de aire

150 mm.

Width
Ancho

860 mm.

Energy class
Clase de energía

-

* The model is exclusively available
in the recirculating version.

* El modelo está disponible sólo en
formato recirculante.



| Speed Velocidad | 1 | 2 | 3 | INT |
|---|-----|-----|-----|-----|
| Air capacity M3H Capacidad de succión | 230 | 345 | 450 | 520 |
| Air capacity CFM Capacidad de succión | 135 | 203 | 264 | 306 |
| Pressure Presión | 360 | 450 | 480 | 500 |
| Input Potencia | 135 | 170 | 215 | 250 |
| Noise level Nivel de ruido | 49 | 60 | 65 | 68 |

Included accessories / Accesorios incluidos

- cod. 112.0157.240 **Charcoal filter**
Filtro de carbón activado
- cod. 112.0157.354 **Remote control**
Control remoto

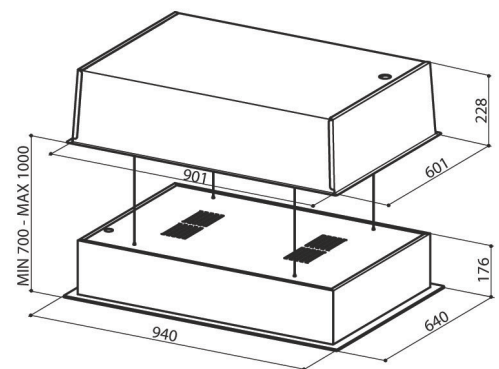

ACCESSORIES

ACCESORIOS



FABER LIGHTING KIT - KIT DE ILUMINACIÓN FABER

KIT 6 LAMP RISP EN 2700 KG9 7W 110V / 60 Hz
cod. 112.0169.137



- Kaleidos
- Vanilla

REMOTE CONTROL - CONTROL REMOTO

cod. 112.0157.354



- Cylindra Isola
- Kaleidos
- Vanilla
- Heaven Glass 2.0
- SkyLift

CHIMNEYS - CHIMENEAS

UPPER
KIT ALTO H990 X cod. 112.0157.252

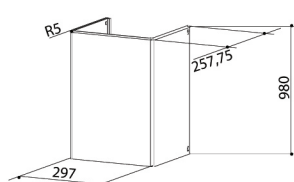

- Stilo

UPPER
KIT A500 + A500 BK Black cod. 112.0250.290

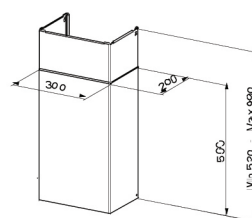

- Cocktail BK

UPPER
KIT ISOLA H990 D370 X cod. 112.0157.267

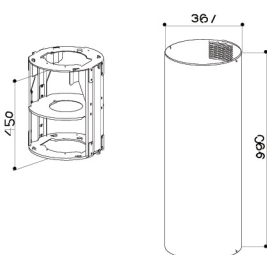

- Cylindra Isola

UPPER
KIT A500 + A500 Stainless Steel cod. 112.0250.289

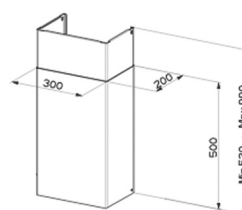

- Cocktail WH

BACKSPLASH

Backsplash X 900 mm. cod. 112.0157.271

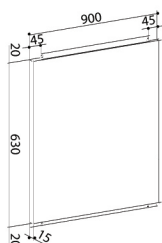

- Stilo

BAFFLE FILTER - FILTRO ANTIGRASA

CONF.1 FILTRO LABERINTO X cod. 112.0157.288



NOTE:
Order 2 or more filters according to hood's width. Please refer to product pages.

NOTA:
Ordene 2 o más filtros según el ancho de la campana. Por favor revise las páginas de los productos.

- Glassy Isola
- Stilo

HFH KIT - KIT HFH

CONF. C.A. HFH cod. 112.0327.631



- Stilo

NOTE:

Usable in location with minimum height of 250 cm.

NOTA:

Aplicable en locaciones con altitud mínima de 250 cm.

CHARCOAL FILTERS - FILTROS DE CARBÓN ACTIVADOS

F8 CONF. 2 C.A.D196 H37 cod. 112.0157.240



- Cocktail
- Heaven Glass 2.0

F9 CONF.1 C.A.STILO-ALTO/2 cod. 112.0157.243



- Cylindra Isola
- Stilo
- Stilo Isola

CHARCOAL FILTERS HIGH PERFORMANCE - FILTROS DE CARBÓN DE ALTO RENDIMIENTO

FHP8 CONF.2 C.A. HIGH PERFORMANCE cod. 112.0158.127



- Cocktail
- Heaven Glass 2.0
- Kaleidos
- Vanilla

HIGH PERFORMANCE

High-efficiency filter with a highly-concentrated carbon micro-granular structure that can guarantee more than 80% filtration capacity of intake fumes and a duration of up to 6 months, double that of a normal charcoal filter, making for economic savings of more than 20%.

ALTO RENDIMIENTO

Filtro de alto rendimiento con una alta concentración de micro granulado de partículas de carbón, garantiza una capacidad de filtración de un 80% del humo y tiene una duración de 6 meses, lo cual es el doble de un filtro de carbón ordinario, dando como resultado más de un 20% de ahorro.



COLLECTION / COLECCIÓN 2016

LA CUISINE
INTERNATIONAL

FABER exclusive representative
Representante exclusivo de FABER

info@lacuisineinternational.com

2005 NW 115TH Avenue, Miami, FL 33172. Tel: 305 418 0010. Fax: 305 463 6733

La Cuisine International - Inspiring Good Living

www.lacuisineinternational.com