

5 Class



Strength & Sophistication

U-Line is proud to introduce, for the first time ever, a line of products featuring stainless steel - inside and out.

The 5 Class Collection of products includes 42 models that showcase exclusive features & industry leading innovations. Key highlights include an industry exclusive full-depth lower interior that maximizes storage options. All models include an industry leading variable speed compressor delivering maximum energy efficiency, faster temperature responses, and quieter operation.



Make it Your Own

Our 5 Class products are designed with the homeowner in mind, paying close attention to details homeowners are looking for such as Slide & Secure™ Bins and soft close doors. Each model features our U-Adjust™ 19-point adjustable interior allowing you to configure wine racks and bins the way you want. With stainless steel and integrated finish options, these products can be used in built-in and freestanding applications. All products are available in 15", 24", and industry exclusive 18" widths for limitless design possibilities.





Stainless Steel

Inside and Out



Variable Speed

State-of-the-Art
Compressor for Power
Efficiency, and Quiet
Operation



Convection Cooling

Quick, Consistent
Temperatures

Full-Depth Lower Interior

Industry Exclusive
Design Allows You to
Maximize Storage
Space

Patent Pending



U-Adjust™

19 Adjustment
Positions for full
Extension Wine
Racks and Slide &
Secure™ Bins to
Contain and Protect



Adjustable LED Lighting

Choose Bright White,
Bold Blue, or a
Combination of Both



HBV515 • 15" Beverage Center • 5 Class



Stainless Frame



Integrated Frame



Integrated Solid

Additional Options

- Accessory panels are designed for easy installation on Integrated models
- Stainless lock model available



Stainless Handleless Panel



Stainless Lock Model

Key Features

- **Industry Exclusive: Full-depth lower interior maximizes storage options**
- **Industry Leading: Variable speed compressor delivers maximum energy efficiency, faster temperature response, and quieter operation**
- Stainless steel interior
- Stainless steel cabinet, toe kick, and accents
- U-Adjust™ Interior: 19 adjustable positions
- Two removable, full-extension Slide & Secure™ Bins
- Two removable, full-extension wine racks
- Convection cooling system provides a quick cool down and consistent temperature
- Temperature range: 33°F - 70°F
- Adjustable bright white or blue LED lighting
- Soft close door with articulating hinge
- Volume of 2.9 cu ft holds up to 8 wine bottles (750 ml) and 34 bottles (12 oz) or 54 cans (12 oz)
- Digital touch pad control with blue LED display
- Stainless steel handle (7/8" diameter)
- Integrated model requires 3/4" custom door panel and handle (not supplied by U-Line)
- Field reversible door is shipped right-hand hinged
- Built-in or freestanding
- Four adjustable leveling legs

MODEL DETAILS

Model	Voltage/Hz	Door Swing	Finish	Shipping Weight
UHBV515-SG01A	115 / 60	Field Reversible	Stainless Frame	105 lb
UHBV515-SG41A	115 / 60	Right-Hand Hinged	Stainless Frame (with lock)	105 lb
UHBV515-SG51A	115 / 60	Left-Hand Hinged	Stainless Frame (with lock)	105 lb
UHBV515-IG01A	115 / 60	Field Reversible	Integrated Frame	103 lb
UHBV515-IS01A	115 / 60	Field Reversible	Integrated Solid	88 lb

ACCESSORIES

Model	Description	Finish	Shipping Weight
ULAGRILLE15	Adjustable Grille (Accepts Integrated Panel)	Black	1.5 lb
ULASHP15FRAME*	Stainless Handleless Panel Frame	Stainless	5 lb
ULASHP15SOLID*	Stainless Handleless Panel Solid	Stainless	6 lb

*Installs on integrated models.

HBV515 • 15" Beverage Center • 5 Class

Dimensions

Front

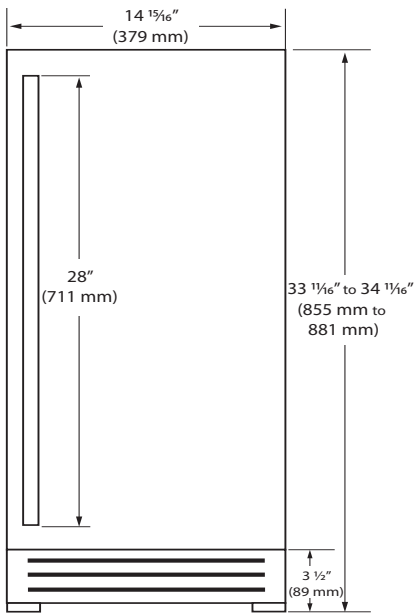

Side

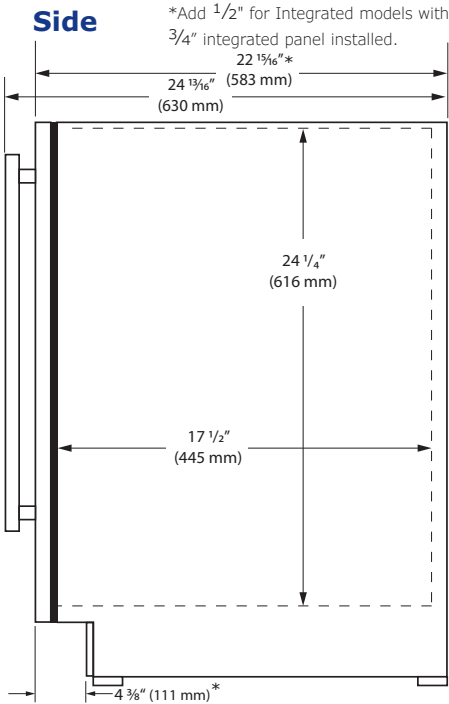

Top

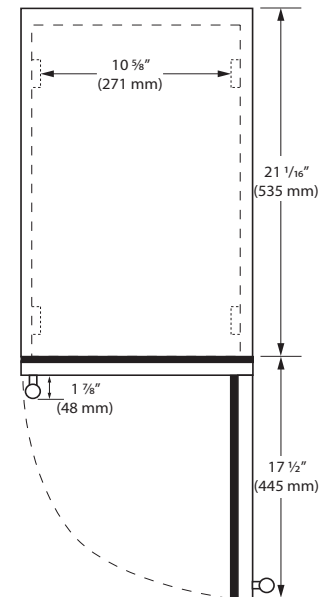

Specifications

Model	HBV515
Amps: Running	1.2
Capacity: Bottle (12 oz)	34
Capacity: Can (12 oz)	54
Capacity: Volume (cu ft)	2.9
Capacity: Wine Bottle (750 ml)	8
Dimensions: Product Depth	22 15/16" / 583 mm
Dimensions: Product Height (Min.)	33 11/16" / 855 mm
Dimensions: Product Width	14 15/16" / 379 mm
Energy Consumption: Avg. Per Year	255 - 285 kWh
ENERGY STAR (glass door)	No
ENERGY STAR (solid door)	Yes
Product Weight: Max	105 lb
Refrigerant Type:	R600a
Sabbath (Star K Certified)	Yes
Temperature Range	33°F - 70°F

Back

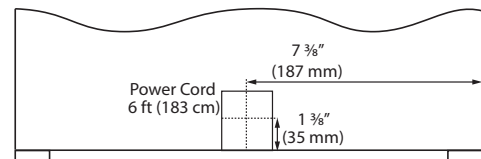

Cabinet Cut-Out

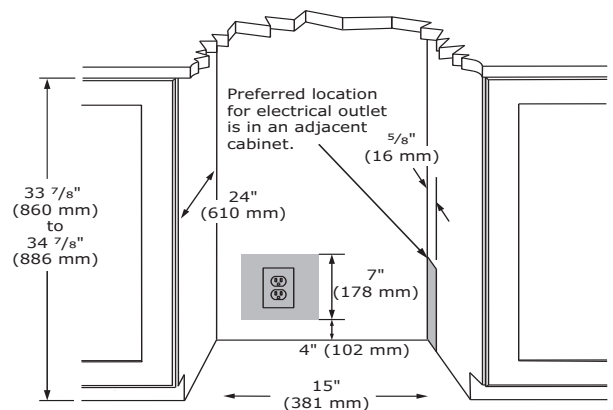

Warranty

- 1 Year (parts & labor) / 5 year sealed system (parts)
- **2 Year (parts & labor) / 5 year sealed system (parts) upgrade at no cost with product registration**



See complete warranty for details

Installation Notes

- No additional clearance is needed for ventilation
- Do not obstruct front grille air flow



HBV518 • 18" Beverage Center • 5 Class



Stainless Frame



Integrated Frame



Integrated Solid

Additional Options

- Accessory panels are designed for easy installation on Integrated models
- Stainless lock model available



Stainless Handleless Panel



Stainless Lock Model

Key Features

- **Industry Exclusive: Full-depth lower interior maximizes storage options**
- **Industry Leading: Variable speed compressor delivers maximum energy efficiency, faster temperature response, and quieter operation**
- Stainless steel interior
- Stainless steel cabinet, toe kick, and accents
- U-Adjust™ Interior: 19 adjustable positions
- Two removable, full-extension Slide & Secure™ Bins
- Two removable, full-extension wine racks
- Convection cooling system provides a quick cool down and consistent temperature
- Temperature range: 33°F - 70°F
- Adjustable bright white or blue LED lighting
- Soft close door with articulating hinge
- Volume of 3.7 cu ft holds up to 10 wine bottles (750 ml) and 45 bottles (12 oz) or 75 cans (12 oz)
- Digital touch pad control with blue LED display
- Stainless steel handle (7/8" diameter)
- Integrated model requires 3/4" custom door panel and handle (not supplied by U-Line)
- Field reversible door is shipped right-hand hinged
- Built-in or freestanding
- Four adjustable leveling legs

MODEL DETAILS

Model	Voltage/Hz	Door Swing	Finish	Shippingw
UHBV518-SG01A	115 / 60	Field Reversible	Stainless Frame	128 lb
UHBV518-SG41A	115 / 60	Right-Hand Hinged	Stainless Frame (with lock)	128 lb
UHBV518-SG51A	115 / 60	Left-Hand Hinged	Stainless Frame (with lock)	128 lb
UHBV518-IG01A	115 / 60	Field Reversible	Integrated Frame	124 lb
UHBV518-IS01A	115 / 60	Field Reversible	Integrated Solid	109 lb

ACCESSORIES

Model	Description	Finish	Shipping Weight
ULAGRILLE18	Adjustable Grille (Accepts Integrated Panel)	Black	1.5 lb
ULASHP18FRAME*	Stainless Handleless Panel Frame	Stainless	8 lb
ULASHP18SOLID*	Stainless Handleless Panel Solid	Stainless	12 lb

*Installs on integrated models.

HBV518 • 18" Beverage Center • 5 Class

Dimensions

Front

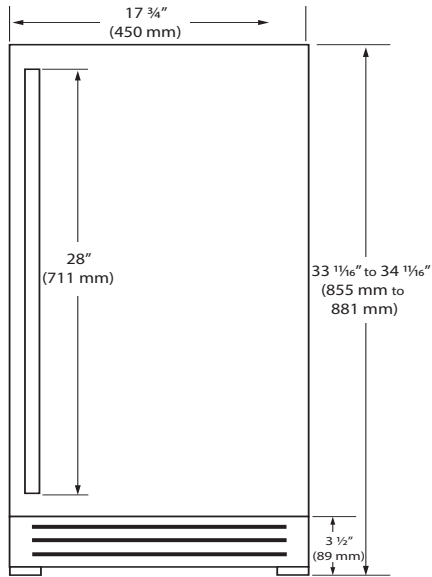

Side

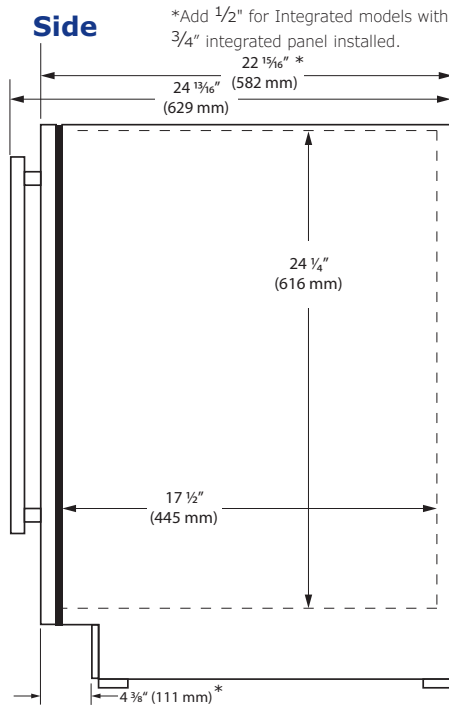

Top

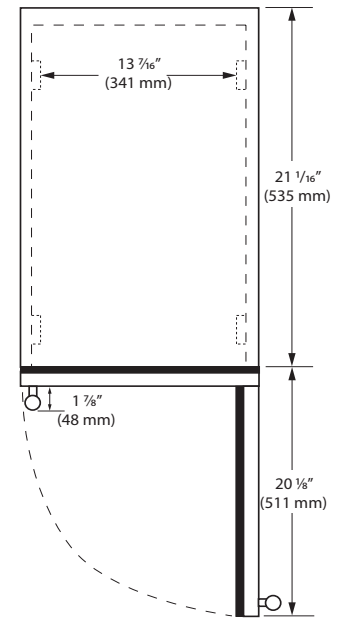

Specifications

Model	HBV518
Amps: Running	1.2
Capacity: Bottle (12 oz)	45
Capacity: Can (12 oz)	75
Capacity: Volume (cu ft)	3.7
Capacity: Wine Bottle (750 ml)	10
Dimensions: Product Depth	22 15/16" / 583 mm
Dimensions: Product Height (Min.)	33 1/16" / 855 mm
Dimensions: Product Width	17 3/4" / 450 mm
Energy Consumption: Avg. Per Year	260 - 290 kWh
ENERGY STAR (glass door)	No
ENERGY STAR (solid door)	Yes
Product Weight: Max	128 lb
Refrigerant Type:	R600a
Sabbath (Star K Certified)	Yes
Temperature Range	33°F - 70°F

Back

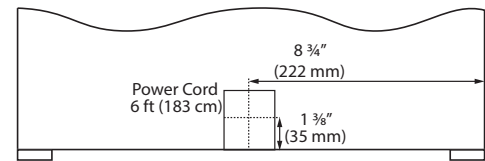

Cabinet Cut-Out

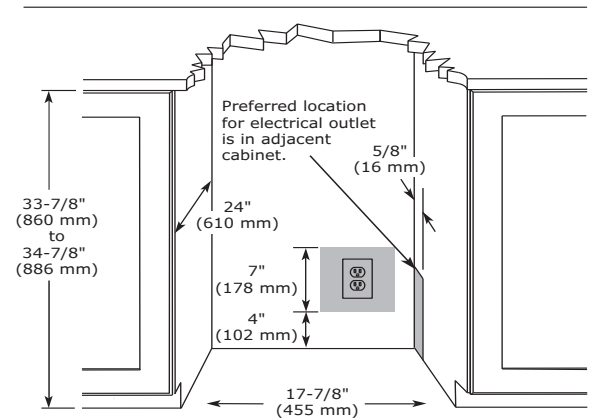

Warranty

- 1 Year (parts & labor) / 5 year sealed system (parts)
- **2 Year (parts & labor) / 5 year sealed system (parts) upgrade at no cost with product registration**



See complete warranty for details

Installation Notes

- No additional clearance is needed for ventilation
- Do not obstruct front grille air flow



HBV524 • 24" Beverage Center • 5 Class



Stainless Frame



Integrated Frame



Integrated Solid

Additional Options

- Accessory panels are designed for easy installation on Integrated models
- Stainless lock model available



Stainless Handleless Panel



Stainless Lock Model

Key Features

- **Industry Exclusive: Full-depth lower interior maximizes storage options**
- **Industry Leading: Variable speed compressor delivers maximum energy efficiency, faster temperature response, and quieter operation**
- Stainless steel interior
- Stainless steel cabinet, toe kick, and accents
- U-Adjust™ Interior: 19 adjustable positions
- Two removable, full-extension Slide & Secure™ Bins
- Two removable, full-extension wine racks
- Convection cooling system provides a quick cool down and consistent temperature
- Temperature range: 33°F - 70°F
- Adjustable bright white or blue LED lighting
- Soft close door with articulating hinge
- Volume of 5.2 cu ft holds up to 14 wine bottles (750 ml) and 68 bottles (12 oz) or 111 cans (12 oz)
- Digital touch pad control with blue LED display
- Stainless steel handle (7/8" diameter)
- Integrated model requires 3/4" custom door panel and handle (not supplied by U-Line)
- Field reversible door is shipped right-hand hinged
- Built-in or freestanding
- Four adjustable leveling legs

MODEL DETAILS

Model	Voltage/Hz	Door Swing	Finish	Shipping Weight
UHBV524-SG01A	115 / 60	Field Reversible	Stainless Frame	163 lb
UHBV524-SG41A	115 / 60	Right-Hand Hinged	Stainless Frame (with lock)	163 lb
UHBV524-SG51A	115 / 60	Left-Hand Hinged	Stainless Frame (with lock)	163 lb
UHBV524-IG01A	115 / 60	Field Reversible	Integrated Frame	156 lb
UHBV524-IS01A	115 / 60	Field Reversible	Integrated Solid	139 lb

ACCESSORIES

Model	Description	Finish	Shipping Weight
ULAGRILLE24	Adjustable Grille (Accepts Integrated Panel)	Black	3 lb
ULASHP24FRAME*	Stainless Handleless Panel Frame	Stainless	10 lb
ULASHP24SOLID*	Stainless Handleless Panel Solid	Stainless	15 lb

HBV524 • 24" Beverage Center • 5 Class

Dimensions

Front

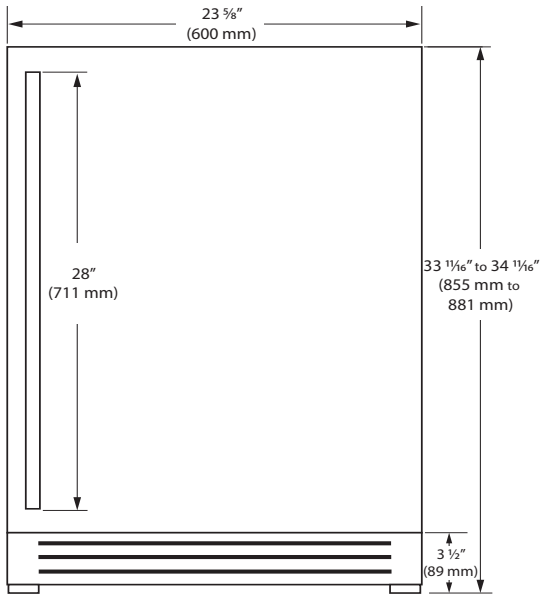

Side

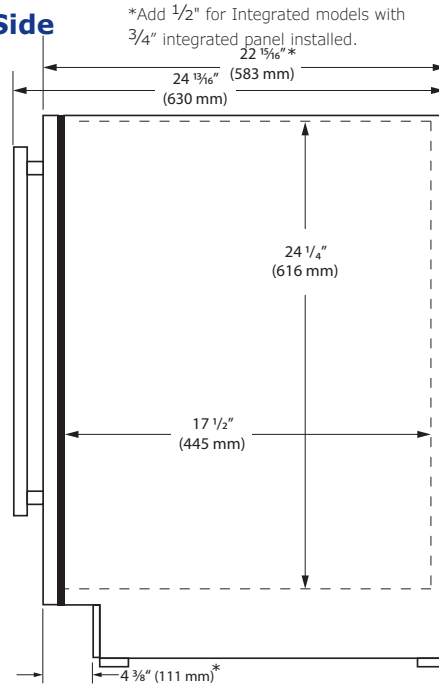

Top

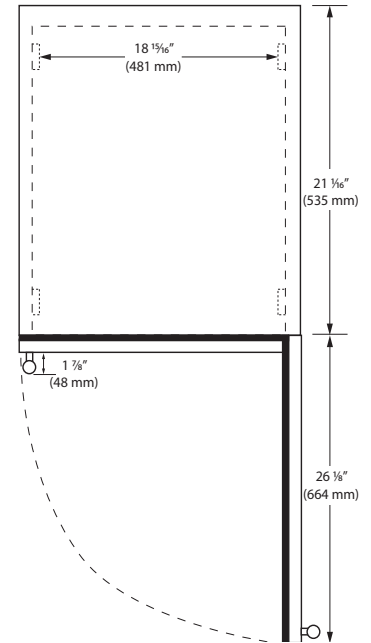

Specifications

Model	HBV524
Amps: Running	1.2
Capacity: Bottle (12 oz)	68
Capacity: Can (12 oz)	111
Capacity: Volume (cu ft)	5.2
Capacity: Wine Bottle (750 ml)	14
Dimensions: Product Depth	22 15/16" / 583 mm
Dimensions: Product Height (Min.)	33 1/16" / 855 mm
Dimensions: Product Width	23 5/8" / 600 mm
Energy Consumption: Avg. Per Year	275 - 305 kWh
ENERGY STAR (glass door)	No
ENERGY STAR (solid door)	Yes
Product Weight: Max	163 lb
Refrigerant Type:	R600a
Sabbath (Star K Certified)	Yes
Temperature Range	33°F - 70°F

Back

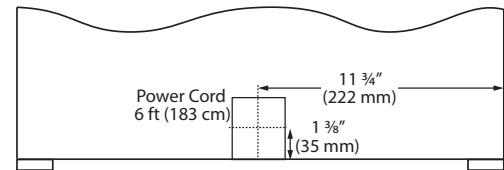

Cabinet Cut-Out

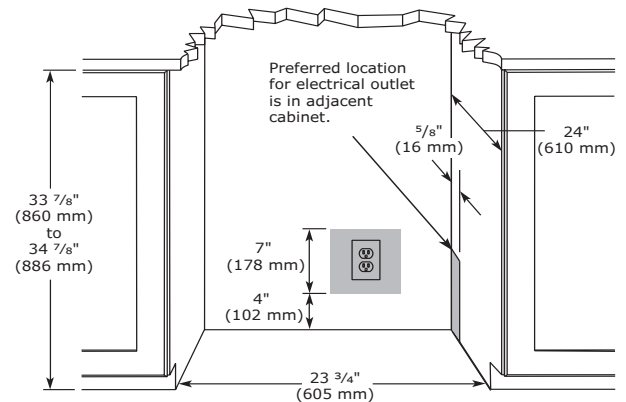

Warranty

- 1 Year (parts & labor) / 5 year sealed system (parts)
- **2 Year (parts & labor) / 5 year sealed system (parts) upgrade at no cost with product registration**



See complete warranty for details

Installation Notes

- No additional clearance is needed for ventilation
- Do not obstruct front grille air flow



HRE515 • 15" Refrigerator • 5 Class



Stainless Frame



Stainless Solid



Integrated Frame



Integrated Solid

Additional Options

- Accessory panels are designed for easy installation on Integrated models



Stainless Handleless Panel

Key Features

- **Industry Exclusive: Full-depth lower interior maximizes storage options**
- **Industry Leading: Variable speed compressor delivers maximum energy efficiency, faster temperature response, and quieter operation**
- Stainless steel interior
- Stainless steel cabinet, toe kick, and accents
- U-Adjust™ Interior: 19 adjustable positions
- Three removable, full-extension Slide & Secure™ Bins
- Convection cooling system provides a quick cool down and consistent temperature
- Temperature range: 33°F - 70°F
- Adjustable bright white or blue LED lighting
- Soft close door with articulating hinge
- Volume of 2.9 cu ft holds up to 47 bottles (12 oz) or 72 cans (12 oz)
- Digital touch pad control with blue LED display
- Stainless steel handle (7/8" diameter)
- Integrated model requires 3/4" custom door panel and handle (not supplied by U-Line)
- Field reversible door is shipped right-hand hinged
- Built-in or freestanding
- Four adjustable leveling legs

MODEL DETAILS

Model	Voltage/Hz	Door Swing	Finish	Shipping Weight
UHRE515-SG01A	115 / 60	Field Reversible	Stainless Frame	105 lb
UHRE515-SS01A	115 / 60	Field Reversible	Stainless Solid	92 lb
UHRE515-IG01A	115 / 60	Field Reversible	Integrated Frame	103 lb
UHRE515-IS01A	115 / 60	Field Reversible	Integrated Solid	88 lb

ACCESSORIES

Model	Description	Finish	Shipping Weight
ULAGRILLE15	Adjustable Grille (Accepts Integrated Panel)	Black	1.5 lb
ULASHP15FRAME*	Stainless Handleless Panel Frame	Stainless	5 lb
ULASHP15SOLID*	Stainless Handleless Panel Solid	Stainless	6 lb

HRE515 • 15" Refrigerator • 5 Class

Dimensions

Front

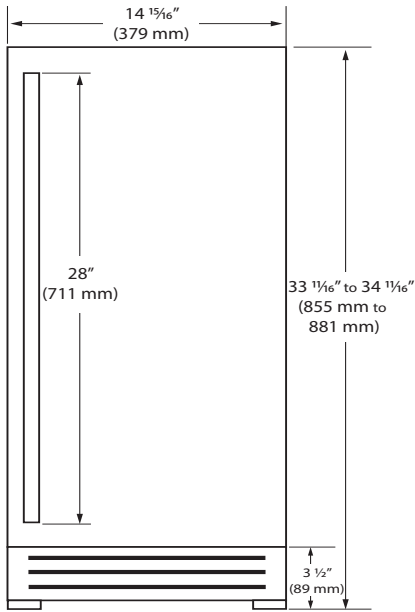

Side

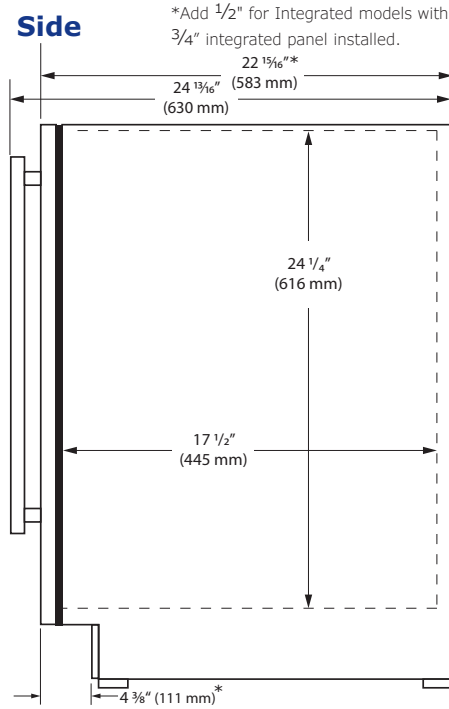

Top

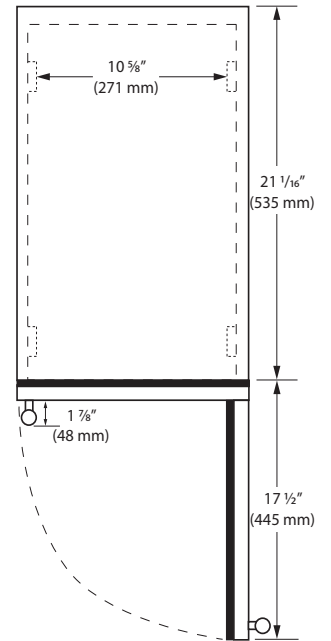

Specifications

Model	HRE515
Amps: Running	1.2
Capacity: Bottle (12 oz)	47
Capacity: Can (12 oz)	72
Capacity: Volume (cu ft)	2.9
Capacity: Wine Bottle (750 ml)	N/A
Dimensions: Product Depth	22 15/16" / 583 mm
Dimensions: Product Height (Min.)	33 11/16" / 855 mm
Dimensions: Product Width	14 15/16" / 379 mm
Energy Consumption: Avg. Per Year	255 - 285 kWh
ENERGY STAR (glass door)	No
ENERGY STAR (solid door)	Yes
Product Weight: Max	105 lb
Refrigerant Type:	R600a
Sabbath (Star K Certified)	Yes
Temperature Range	33°F - 70°F

Back

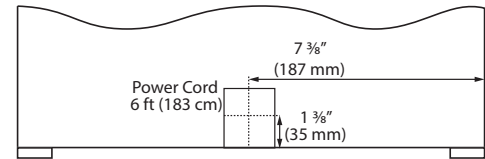

Cabinet Cut-Out

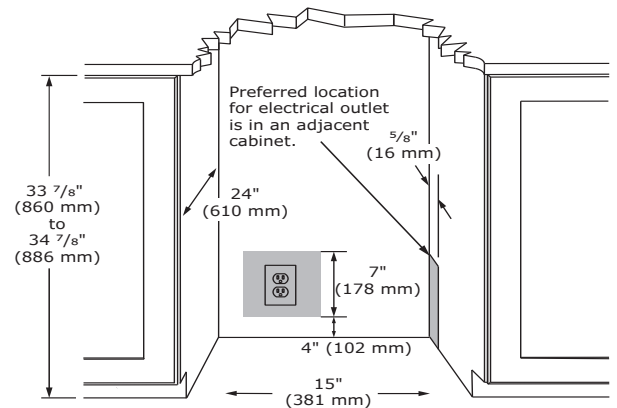

Warranty

- 1 Year (parts & labor) / 5 year sealed system (parts)
- **2 Year (parts & labor) / 5 year sealed system (parts) upgrade at no cost with product registration**



See complete warranty for details

Installation Notes

- No additional clearance is needed for ventilation
- Do not obstruct front grille air flow



HRE518 • 18" Refrigerator • 5 Class



Additional Options

- Accessory panels are designed for easy installation on Integrated models



Stainless Handleless Panel

Key Features

- **Industry Exclusive: Full-depth lower interior maximizes storage options**
- **Industry Leading: Variable speed compressor delivers maximum energy efficiency, faster temperature response, and quieter operation**
- Stainless steel interior
- Stainless steel cabinet, toe kick, and accents
- U-Adjust™ Interior: 19 adjustable positions
- Three removable, full-extension Slide & Secure™ Bins
- Convection cooling system provides a quick cool down and consistent temperature
- Temperature range: 33°F - 70°F
- Adjustable bright white or blue LED lighting
- Soft close door with articulating hinge
- Volume of 3.7 cu ft holds up to 61 bottles (12 oz) or 100 cans (12 oz)
- Digital touch pad control with blue LED display
- Stainless steel handle (7/8" diameter)
- Integrated model requires 3/4" custom door panel and handle (not supplied by U-Line)
- Field reversible door is shipped right-hand hinged
- Built-in or freestanding
- Four adjustable leveling legs

MODEL DETAILS

Model	Voltage/Hz	Door Swing	Finish	Shipping Weight
UHRE518-SG01A	115 / 60	Field Reversible	Stainless Frame	128 lb
UHRE518-SS01A	115 / 60	Field Reversible	Stainless Solid	115 lb
UHRE518-IG01A	115 / 60	Field Reversible	Integrated Frame	124 lb
UHRE518-IS01A	115 / 60	Field Reversible	Integrated Solid	109 lb

ACCESSORIES

Model	Description	Finish	Shipping Weight
ULAGRILLE18	Adjustable Grille (Accepts Integrated Panel)	Black	1.5 lb
ULASHP18FRAME*	Stainless Handleless Panel Frame	Stainless	8 lb
ULASHP18SOLID*	Stainless Handleless Panel Solid	Stainless	12 lb

HRE518 • 18" Refrigerator • 5 Class

Dimensions

Front

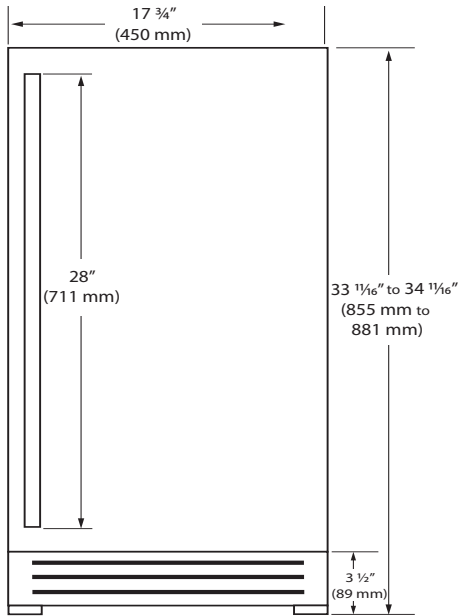

Side

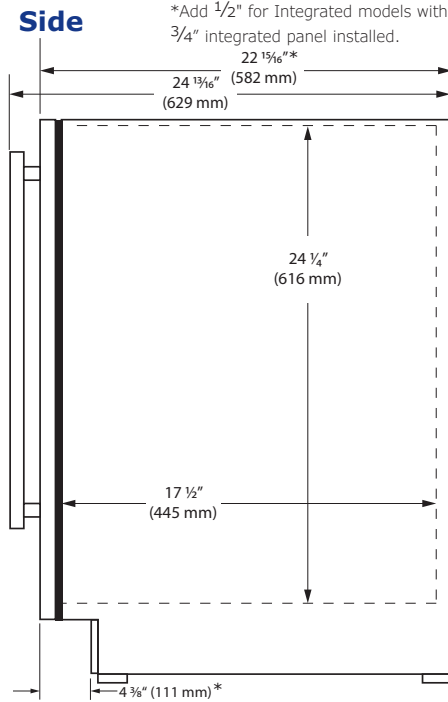

Top

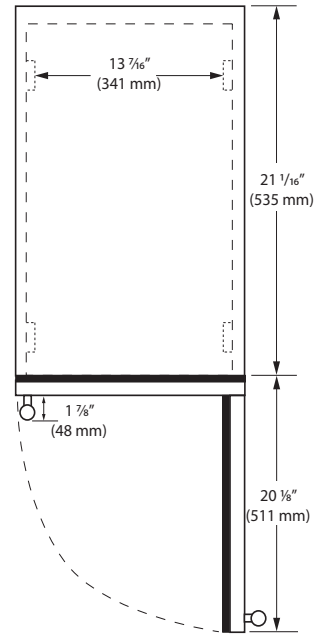

Specifications

Model	HRE518
Amps: Running	1.2
Capacity: Bottle (12 oz)	61
Capacity: Can (12 oz)	100
Capacity: Volume (cu ft)	3.7
Capacity: Wine Bottle (750 ml)	N/A
Dimensions: Product Depth	22 15/16" / 583 mm
Dimensions: Product Height (Min.)	33 1/16" / 855 mm
Dimensions: Product Width	17 3/4" / 450 mm
Energy Consumption: Avg. Per Year	260 - 290 kWh
ENERGY STAR (glass door)	No
ENERGY STAR (solid door)	Yes
Product Weight: Max	128 lb
Refrigerant Type:	R600a
Sabbath (Star K Certified)	Yes
Temperature Range	33°F - 70°F

Back

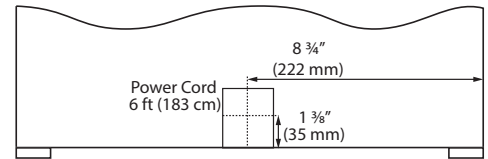

Cabinet Cut-Out

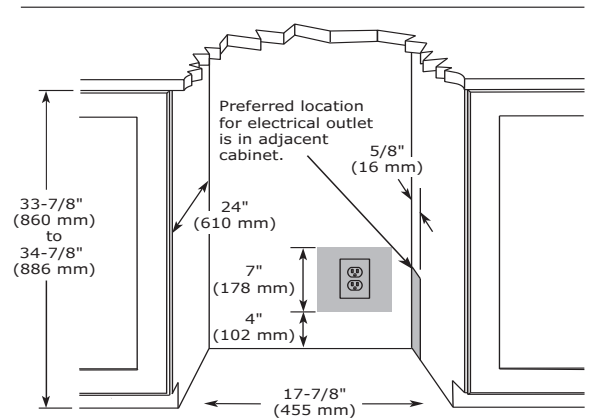

Warranty

- 1 Year (parts & labor) / 5 year sealed system (parts)
- **2 Year (parts & labor) / 5 year sealed system (parts) upgrade at no cost with product registration**



See complete warranty for details

Installation Notes

- No additional clearance is needed for ventilation
- Do not obstruct front grille air flow



HRE524 • 24" Refrigerator • 5 Class



Stainless Frame Stainless Solid Integrated Frame Integrated Solid

Additional Options

- Accessory panels are designed for easy installation on Integrated models



Stainless Handleless Panel

Key Features

- **Industry Exclusive: Full-depth lower interior maximizes storage options**
- **Industry Leading: Variable speed compressor delivers maximum energy efficiency, faster temperature response, and quieter operation**
- Stainless steel interior
- Stainless steel cabinet, toe kick, and accents
- U-Adjust™ Interior: 19 adjustable positions
- Three removable, full-extension Slide & Secure™ Bins
- Convection cooling system provides a quick cool down and consistent temperature
- Temperature range: 33°F - 70°F
- Adjustable bright white or blue LED lighting
- Soft close door with articulating hinge
- Volume of 5.2 cu ft holds up to 94 bottles (12 oz) or 148 cans (12 oz)
- Digital touch pad control with blue LED display
- Stainless steel handle (7/8" diameter)
- Integrated model requires 3/4" custom door panel and handle (not supplied by U-Line)
- Field reversible door is shipped right-hand hinged
- Built-in or freestanding
- Four adjustable leveling legs

MODEL DETAILS

Model	Voltage/Hz	Door Swing	Finish	Shipping Weight
UHRE524-SG01A	115 / 60	Field Reversible	Stainless Frame	163 lb
UHRE524-SS01A	115 / 60	Field Reversible	Stainless Solid	148 lb
UHRE524-IG01A	115 / 60	Field Reversible	Integrated Frame	156 lb
UHRE524-IS01A	115 / 60	Field Reversible	Integrated Solid	139 lb

ACCESSORIES

Model	Description	Finish	Shipping Weight
ULAGRILLE24	Adjustable Grille (Accepts Integrated Panel)	Black	3 lb
ULASHP24FRAME*	Stainless Handleless Panel Frame	Stainless	10 lb
ULASHP24SOLID*	Stainless Handleless Panel Solid	Stainless	15 lb

*Installs on integrated models.

HRE524 • 24" Refrigerator • 5 Class

Dimensions

Front

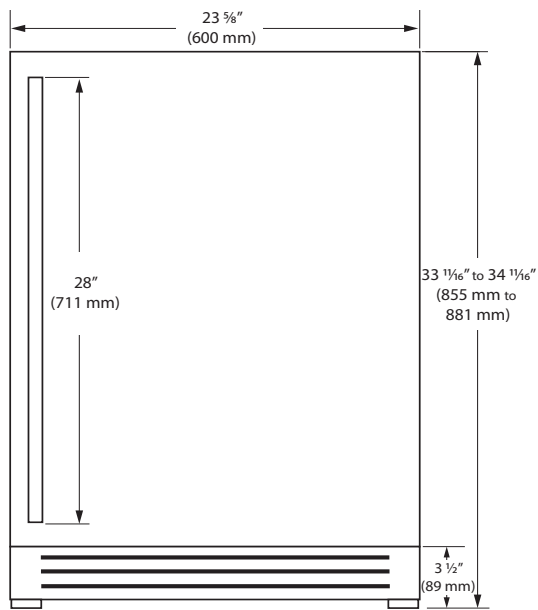

Side

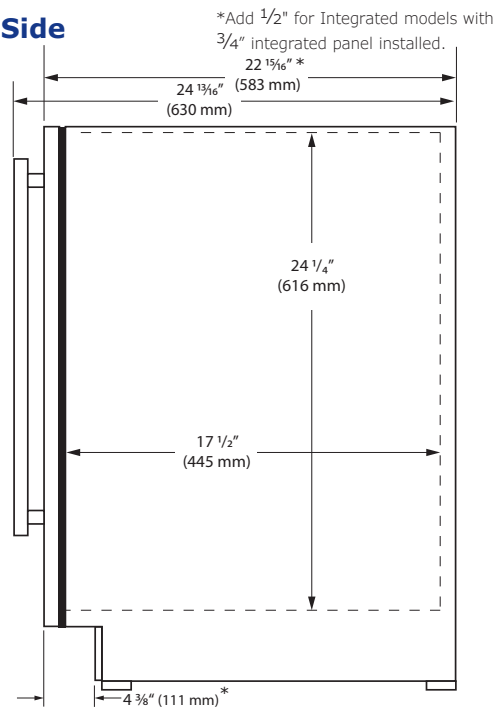

Top

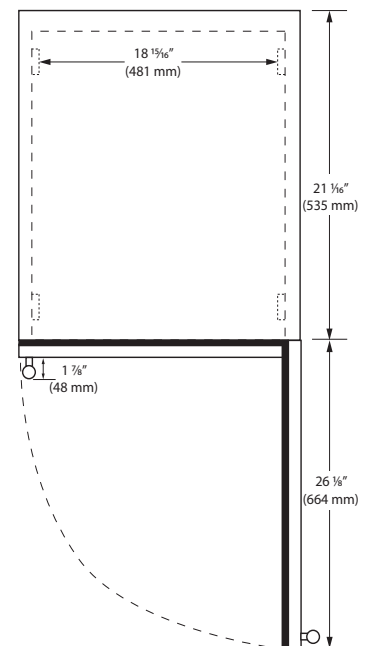

Specifications

Model	HRE524
Amps: Running	1.2
Capacity: Bottle (12 oz)	94
Capacity: Can (12 oz)	148
Capacity: Volume (cu ft)	5.2
Capacity: Wine Bottle (750 ml)	N/A
Dimensions: Product Depth	22 15/16" / 583 mm
Dimensions: Product Height (Min.)	33 1/16" / 855 mm
Dimensions: Product Width	14 15/16" / 379 mm
Energy Consumption: Avg. Per Year	275 - 305 kWh
ENERGY STAR (glass door)	No
ENERGY STAR (solid door)	Yes
Product Weight: Max	163 lb
Refrigerant Type:	R600a
Sabbath (Star K Certified)	Yes
Temperature Range	33°F - 70°F

Back

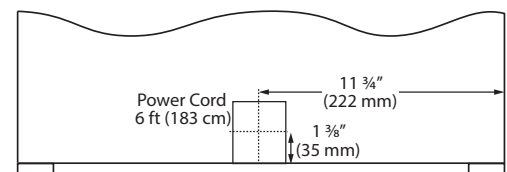

Cabinet Cut-Out

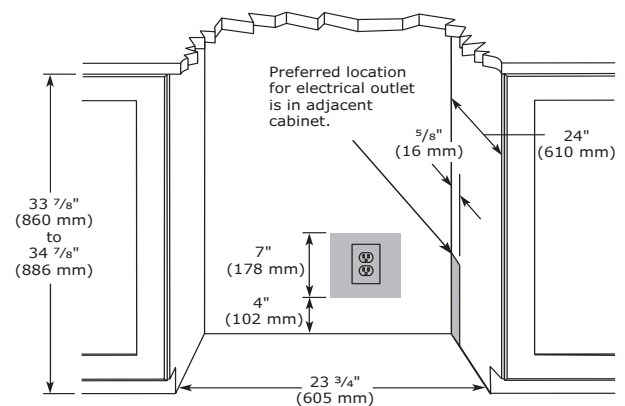

Warranty

- 1 Year (parts & labor) / 5 year sealed system (parts)
- **2 Year (parts & labor) / 5 year sealed system (parts) upgrade at no cost with product registration**



See complete warranty for details

Installation Notes

- No additional clearance is needed for ventilation
- Do not obstruct front grille air flow



HWC515 • 15" Wine Captain • 5 Class



Stainless Frame



Integrated Frame



Integrated Solid

Additional Options

- Accessory panels are designed for easy installation on Integrated models
- Stainless lock model available



Stainless Handleless Panel



Stainless Lock Model

Key Features

- **Industry Exclusive: Full-depth lower interior maximizes storage options**
- **Industry Leading: Variable speed compressor delivers maximum energy efficiency, faster temperature response, and quieter operation**
- Stainless steel interior
- Stainless steel cabinet, toe kick, and accents
- U-Adjust™ Interior: 19 adjustable positions
- Seven removable, full-extension wine racks
- Wine racks accommodate a variety of bottle shapes and sizes and can be configured to store champagne and magnum bottles
- Convection cooling system provides a quick cool down and consistent temperature
- Temperature range: 33°F - 70°F
- Adjustable bright white or blue LED lighting
- Soft close door with articulating hinge
- Volume of 2.9 cu ft holds up to 28 wine bottles (750 ml)
- Digital touch pad control with blue LED display
- Stainless steel handle (7/8" diameter)
- Integrated model requires 3/4" custom door panel and handle (not supplied by U-Line)
- Field reversible door is shipped right-hand hinged
- Built-in or freestanding
- Four adjustable leveling legs

MODEL DETAILS

Model	Voltage/Hz	Door Swing	Finish	Shipping Weight
UHC515-SG01A	115 / 60	Field Reversible	Stainless Frame	105 lb
UHC515-SG41A	115 / 60	Right-Hand Hinged	Stainless Frame (with lock)	105 lb
UHC515-SG51A	115 / 60	Left-Hand Hinged	Stainless Frame (with lock)	105 lb
UHC515-IG01A	115 / 60	Field Reversible	Integrated Frame	103 lb
UHC515-IS01A	115 / 60	Field Reversible	Integrated Solid	88 lb

ACCESSORIES

Model	Description	Finish	Shipping Weight
ULAGRILLE15	Adjustable Grille (Accepts Integrated Panel)	Black	1.5 lb
ULASHP15FRAME*	Stainless Handleless Panel Frame	Stainless	5 lb
ULASHP15SOLID*	Stainless Handleless Panel Solid	Stainless	6 lb

HWC515 • 15" Wine Captain • 5 Class

Dimensions

Front

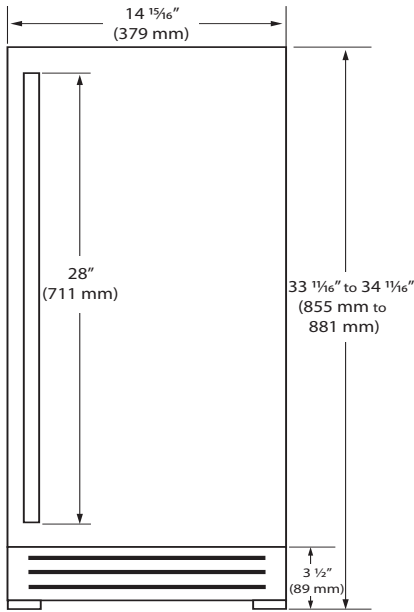

Side

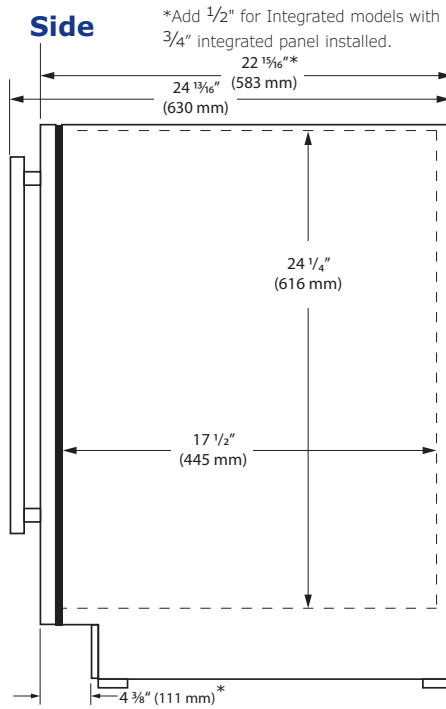

Top

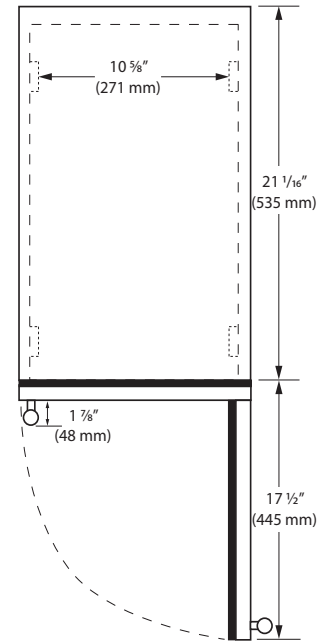

Specifications

Model	HWC515
Amps: Running	1.2
Capacity: Bottle (12 oz)	N/A
Capacity: Can (12 oz)	N/A
Capacity: Volume (cu ft)	2.9
Capacity: Wine Bottle (750 ml)	28
Dimensions: Product Depth	22 15/16" / 583 mm
Dimensions: Product Height (Min.)	33 11/16" / 855 mm
Dimensions: Product Width	14 15/16" / 379 mm
Energy Consumption: Avg. Per Year	255 - 285 kWh
ENERGY STAR (glass door)	No
ENERGY STAR (solid door)	Yes
Product Weight: Max	105 lb
Refrigerant Type:	R600a
Sabbath (Star K Certified)	Yes
Temperature Range	33°F - 70°F

Back

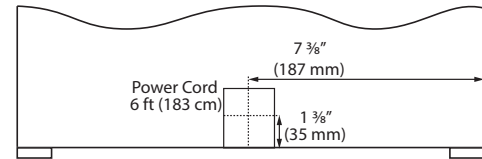

Cabinet Cut-Out

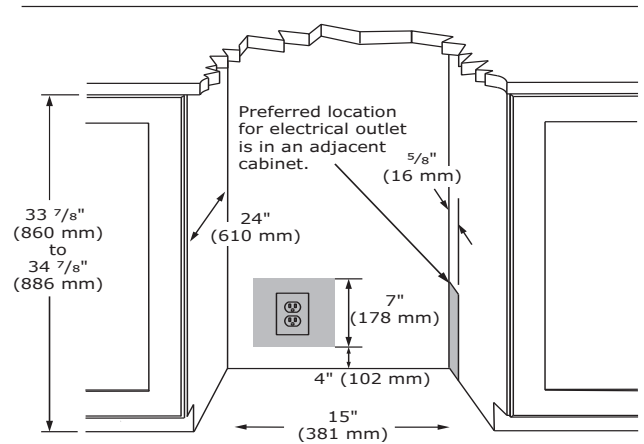

Warranty

- 1 Year (parts & labor) / 5 year sealed system (parts)
- **2 Year (parts & labor) / 5 year sealed system (parts) upgrade at no cost with product registration**



See complete warranty for details

Installation Notes

- No additional clearance is needed for ventilation
- Do not obstruct front grille air flow



HWC518 • 18" Wine Captain • 5 Class



Stainless Frame



Integrated Frame



Integrated Solid

Additional Options

- Accessory panels are designed for easy installation on Integrated models
- Stainless lock model available



Stainless Handleless Panel



Stainless Lock Model

Key Features

- **Industry Exclusive: Full-depth lower interior maximizes storage options**
- **Industry Leading: Variable speed compressor delivers maximum energy efficiency, faster temperature response, and quieter operation**
- Stainless steel interior
- Stainless steel cabinet, toe kick, and accents
- U-Adjust™ Interior: 19 adjustable positions
- Seven removable, full-extension wine racks
- Wine racks accommodate a variety of bottle shapes and sizes and can be configured to store champagne and magnum bottles
- Convection cooling system provides a quick cool down and consistent temperature
- Temperature range: 33°F - 70°F

- Adjustable bright white or blue LED lighting
- Soft close door with articulating hinge
- Volume of 3.7 cu ft holds up to 35 wine bottles (750 ml)
- Digital touch pad control with blue LED display
- Stainless steel handle (7/8" diameter)
- Integrated model requires 3/4" custom door panel and handle (not supplied by U-Line)
- Field reversible door is shipped right-hand hinged
- Built-in or freestanding
- Four adjustable leveling legs

MODEL DETAILS

Model	Voltage/Hz	Door Swing	Finish	Shipping Weight
UHWC518-SG01A	115 / 60	Field Reversible	Stainless Frame	128 lb
UHWC518-SG41A	115 / 60	Right-Hand Hinged	Stainless Frame (with lock)	128 lb
UHWC518-SG51A	115 / 60	Left-Hand Hinged	Stainless Frame (with lock)	128 lb
UHWC518-IG01A	115 / 60	Field Reversible	Integrated Frame	124 lb
UHWC518-IS01A	115 / 60	Field Reversible	Integrated Solid	109 lb

ACCESSORIES

Model	Description	Finish	Shipping Weight
ULAGRILLE18	Adjustable Grille (Accepts Integrated Panel)	Black	1.5 lb
ULASHP18FRAME*	Stainless Handleless Panel Frame	Stainless	8 lb
ULASHP18SOLID*	Stainless Handleless Panel Solid	Stainless	12 lb

*Installs on integrated models.

HWC518 • 18" Wine Captain • 5 Class

Dimensions

Front

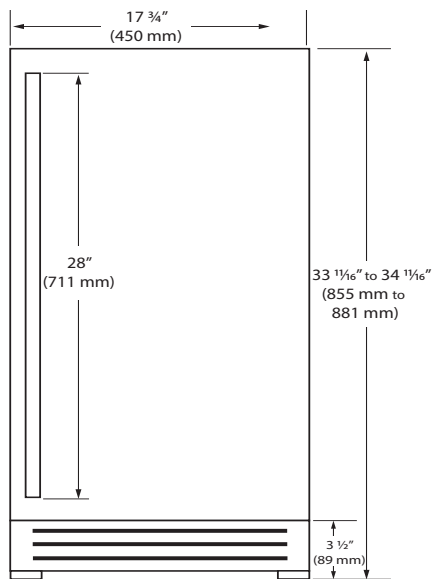

Side

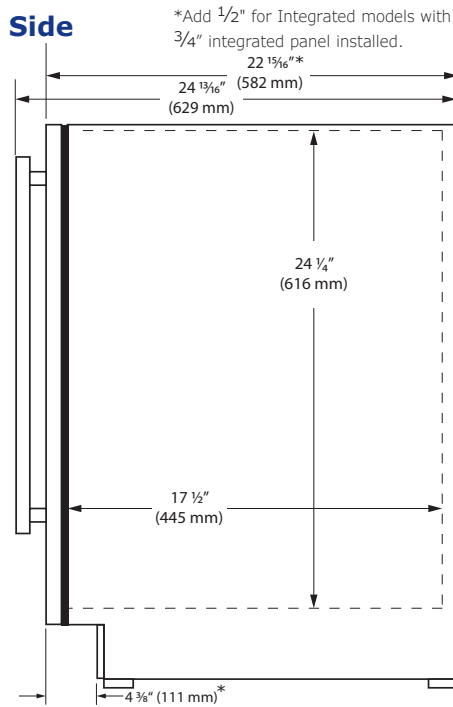

Top

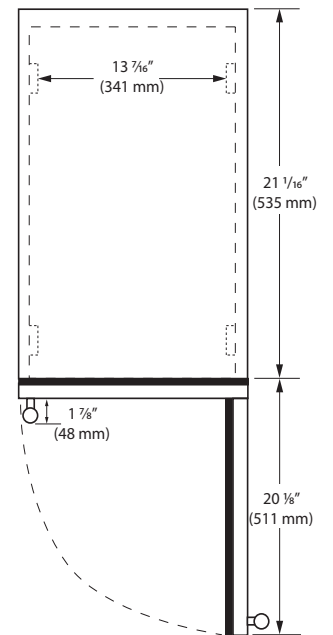

Specifications

Model	HWC518
Amps: Running	1.2
Capacity: Bottle (12 oz)	N/A
Capacity: Can (12 oz)	N/A
Capacity: Volume (cu ft)	3.7
Capacity: Wine Bottle (750 ml)	35
Dimensions: Product Depth	22 15/16" / 583 mm
Dimensions: Product Height (Min.)	33 1/16" / 855 mm
Dimensions: Product Width	17 3/4" / 450 mm
Energy Consumption: Avg. Per Year	260 - 290 kWh
ENERGY STAR (glass door)	No
ENERGY STAR (solid door)	Yes
Product Weight: Max	128 lb
Refrigerant Type:	R600a
Sabbath (Star K Certified)	Yes
Temperature Range	33°F - 70°F

Back

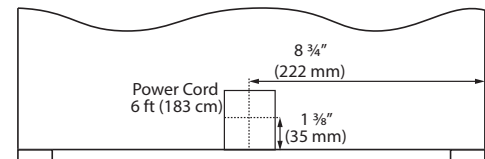

Cabinet Cut-Out

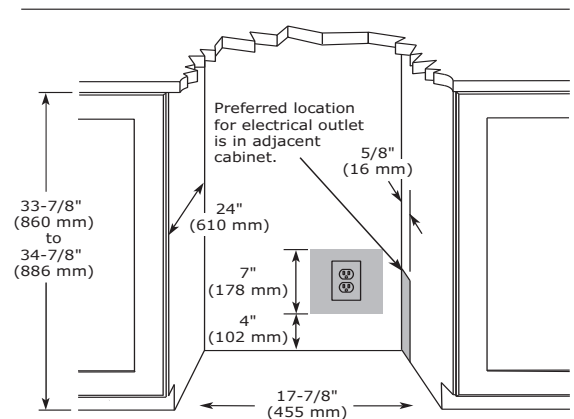

Warranty

- 1 Year (parts & labor) / 5 year sealed system (parts)
- **2 Year (parts & labor) / 5 year sealed system (parts) upgrade at no cost with product registration**



See complete warranty for details

Installation Notes

- No additional clearance is needed for ventilation
- Do not obstruct front grille air flow



HWC524 • 24" Wine Captain • 5 Class



Stainless Frame



Integrated Frame



Integrated Solid

Additional Options

- Accessory panels are designed for easy installation on Integrated models
- Stainless lock model available



Stainless Handleless Panel



Stainless Lock Model

Key Features

- **Industry Exclusive: Full-depth lower interior maximizes storage options**
- **Industry Leading: Variable speed compressor delivers maximum energy efficiency, faster temperature response, and quieter operation**
- Stainless steel interior
- Stainless steel cabinet, toe kick, and accents
- U-Adjust™ Interior: 19 adjustable positions
- Seven removable, full-extension wine racks
- Wine racks accommodate a variety of bottle shapes and sizes and can be configured to store champagne and magnum bottles
- Convection cooling system provides a quick cool down and consistent temperature
- Temperature range: 33°F - 70°F
- Adjustable bright white or blue LED lighting
- Soft close door with articulating hinge
- Volume of 5.2 cu ft holds up to 49 wine bottles (750 ml)
- Digital touch pad control with blue LED display
- Stainless steel handle (7/8" diameter)
- Integrated model requires 3/4" custom door panel and handle (not supplied by U-Line)
- Field reversible door is shipped right-hand hinged
- Built-in or freestanding
- Four adjustable leveling legs

MODEL DETAILS

Model	Voltage/Hz	Door Swing	Finish	Shipping Weight
UHWC524-SG01A	115 / 60	Field Reversible	Stainless Frame	163 lb
UHWC524-SG41A	115 / 60	Right-Hand Hinged	Stainless Frame (with lock)	163 lb
UHWC524-SG51A	115 / 60	Left-Hand Hinged	Stainless Frame (with lock)	163 lb
UHWC524-IG01A	115 / 60	Field Reversible	Integrated Frame	156 lb
UHWC524-IS01A	115 / 60	Field Reversible	Integrated Solid	139 lb

ACCESSORIES

Model	Description	Finish	Shipping Weight
ULAGRILLE24	Adjustable Grille (Accepts Integrated Panel)	Black	3 lb
ULASHP24FRAME*	Stainless Handleless Panel Frame	Stainless	10 lb
ULASHP24SOLID*	Stainless Handleless Panel Solid	Stainless	15 lb

*Installs on integrated models.

HWC524 • 24" Wine Captain • 5 Class

Dimensions

Front

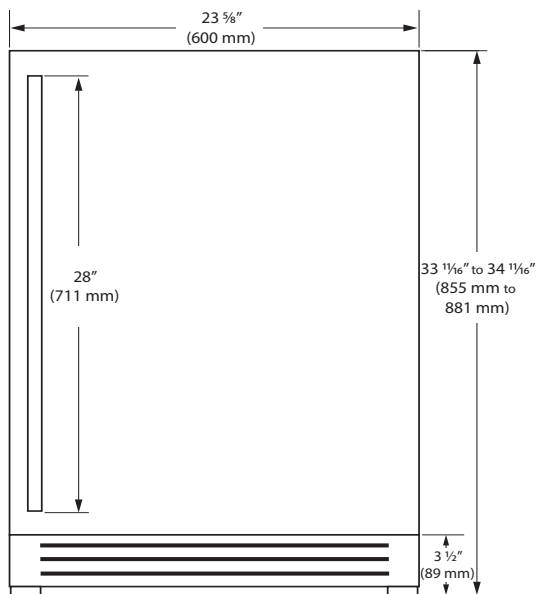

Side

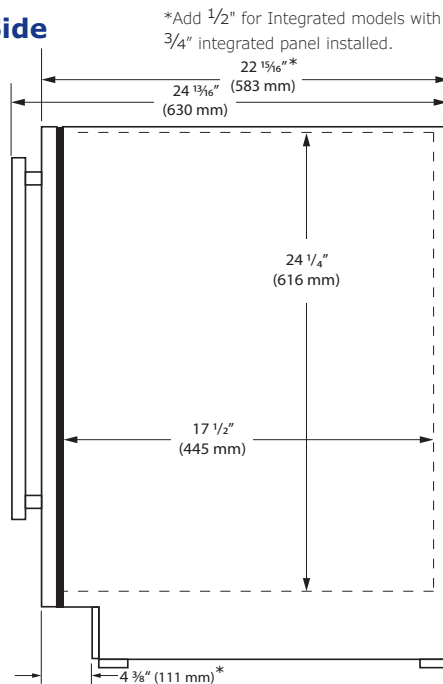

Top

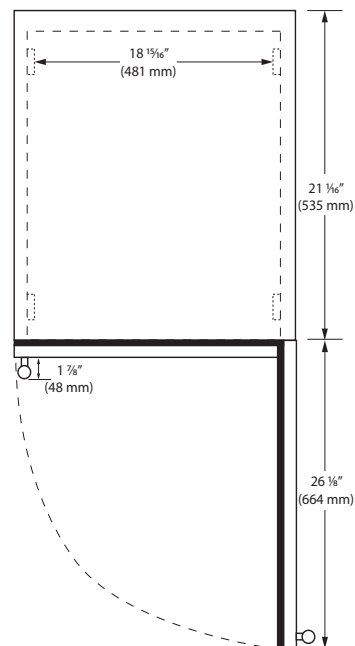

Specifications

Model	HWC524
Amps: Running	1.2
Capacity: Bottle (12 oz)	N/A
Capacity: Can (12 oz)	N/A
Capacity: Volume (cu ft)	5.2
Capacity: Wine Bottle (750 ml)	49
Dimensions: Product Depth	22 15/16" / 583 mm
Dimensions: Product Height (Min.)	33 1/16" / 855 mm
Dimensions: Product Width	23 5/8" / 600 mm
Energy Consumption: Avg. Per Year	275 - 305 kWh
ENERGY STAR (glass door)	No
ENERGY STAR (solid door)	Yes
Product Weight: Max	163 lb
Refrigerant Type:	R600a
Sabbath (Star K Certified)	Yes
Temperature Range	33°F - 70°F

Back

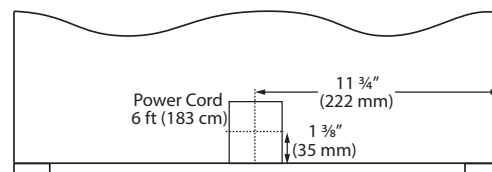

Cabinet Cut-Out

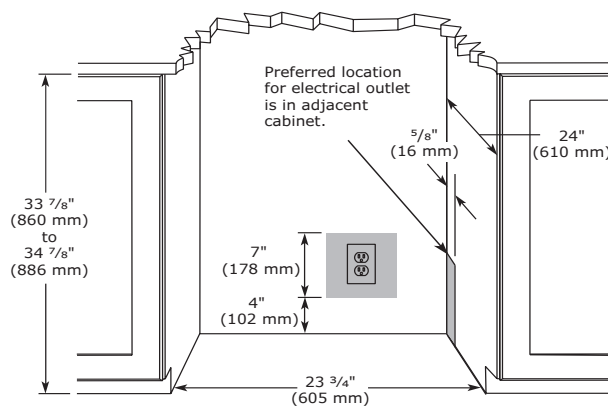

Warranty

- 1 Year (parts & labor) / 5 year sealed system (parts)
- **2 Year (parts & labor) / 5 year sealed system (parts) upgrade at no cost with product registration**



See complete warranty for details

Installation Notes

- No additional clearance is needed for ventilation
- Do not obstruct front grille air flow





U-LINE

RIGHT PRODUCT. RIGHT PLACE. RIGHT TEMPERATURE. SINCE 1962.

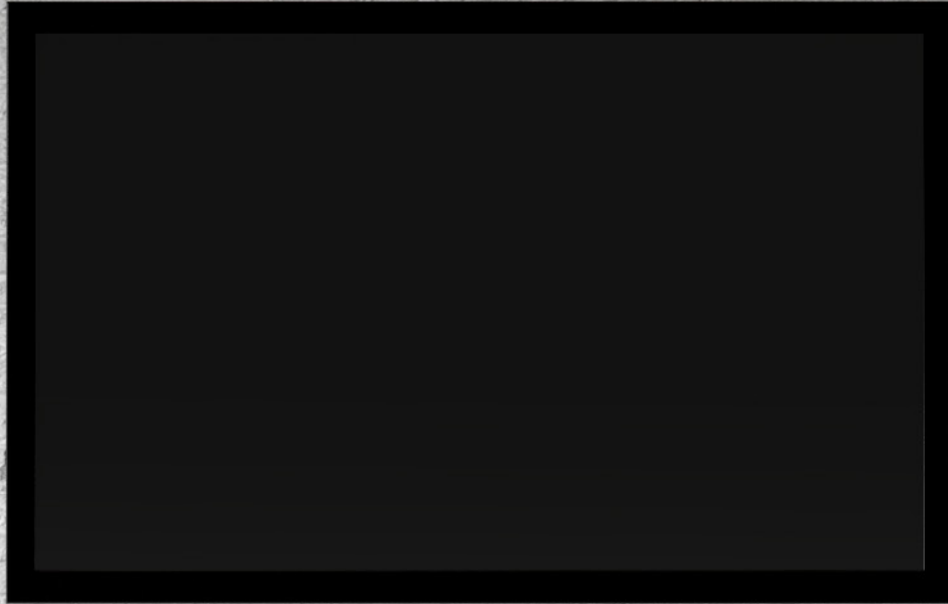

Beverage Centers • Wine Captain® Models • Ice Machines • Refrigerators • Freezers

u-line.com • +1.414.354.0300 • sales@u-line.com • 