

# Nugget Ice Machine Collection



# Nugget Ice Machines Designed With in Mind.

U-Line is excited to introduce a brand new collection of Nugget Ice Machines. Our Nugget Ice Machines provide unsurpassed performance with industry exclusive features such as the highest ice production of up to 90 lbs. of ice per day, models with U-Choose™ ice adjustability, and premium models with interior water dispensers. We designed this collection in collaboration with Follett® LLC, the world leader in commercial nugget ice technology. Options include indoor, outdoor, and ADA height compliant models that can be built-in or freestanding to personalize your space.

The addition of the Nugget Ice Machine Collection further solidifies U-Line as the leader in undercounter ice products. We patented the first residential Crescent Ice Maker in 1962, and in 1998 introduced our Clear Ice Machine.

To ensure the highest quality in the industry, every ice machine undergoes a minimum of overnight ice production and a 40+ point inspection. All U-Line Ice Machines are designed, engineered, and assembled in Milwaukee, Wisconsin, USA.



# Ice Production & Capacity

Up to 90 lbs. of Ice Per Day  
With 30 lbs. of Storage



# U-Choose™

Select From Five Levels  
of Ice Density

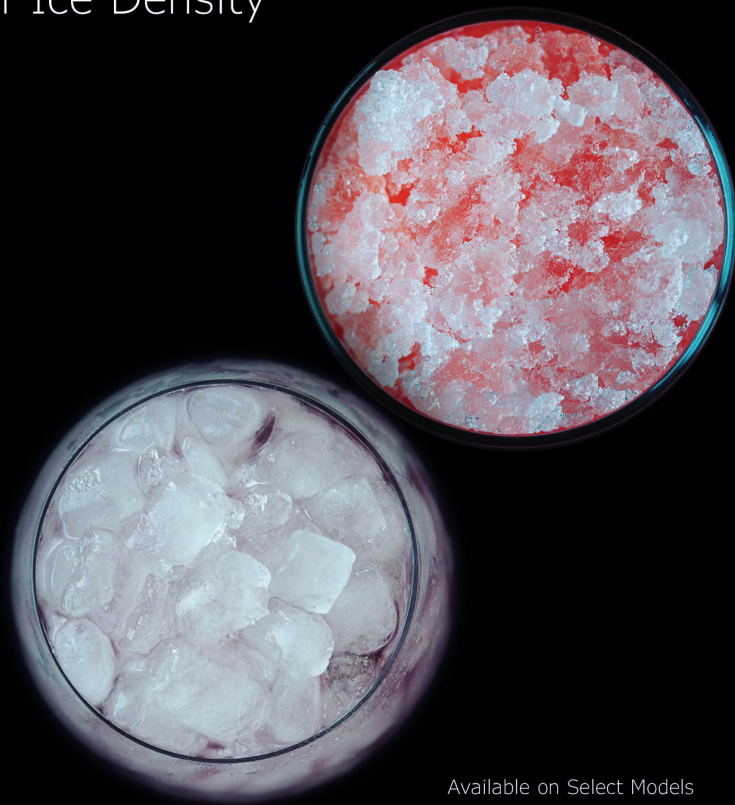

Available on Select Models

# Filtered Water On Demand



Available on Select Models

# Adjustable LED Lighting

From Bright White to  
Bold Blue

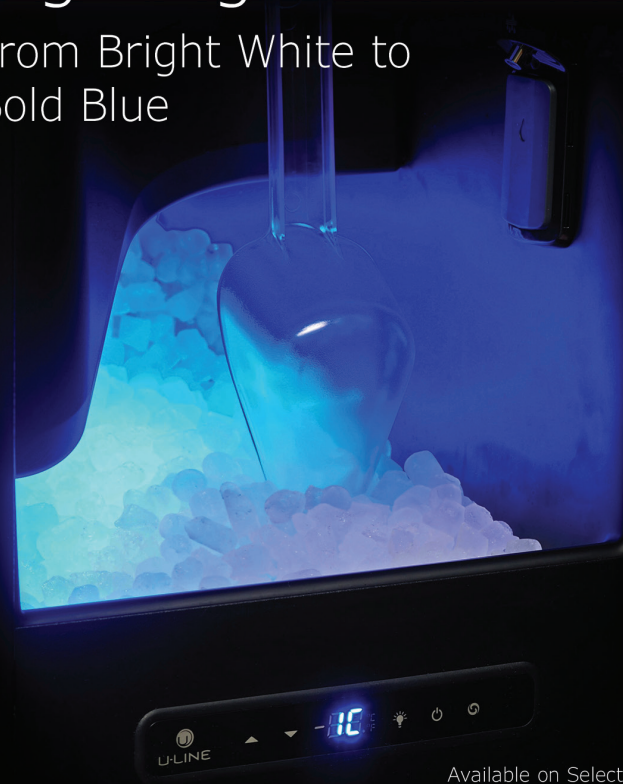

Available on Select Models



Stainless Solid

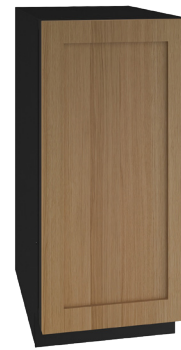

Integrated Solid

### Key Features

- **Industry Exclusive: U-Choose™ feature offers five levels of ice density**
- **Industry Exclusive: Interior water dispenser**
- **Industry Exclusive: Single water filter for ice and water**
- **Industry Leading: Produces up to 90 lb of ice per day**
- **Industry Leading: Stores 30 lb of ice**
- Makes cylindrical compressed ice bits approx. 3/4" L x 1/2" H
- Eco friendly - most efficient type of specialty ice
- Adjustable bright white or blue LED lighting
- Soft close door with articulating hinge
- Black interior
- Digital touch pad control with blue LED display
- Indicator alert notifies user when cleaning is needed
- Stainless steel handle (7/8" diameter)
- Easiest nugget ice machine cleaning process in the industry
- Integrated model requires 3/4" custom door panel and handle (not supplied by U-Line)
- Field reversible door is shipped right-hand hinged
- Built-in or freestanding
- Four adjustable leveling legs
- Factory installed drain pump model recommended if a gravity drain is not accessible

### Model Details

Model	Voltage/Hz	Door Swing	Pump	Finish	Shipping Weight
UHNB315-SS01A	115 / 60	Field Reversible	-	Stainless Solid	107 lb
UHNP315-SS01A	115 / 60	Field Reversible	Pump Included	Stainless Solid	112 lb
UHNB315-IS01A	115 / 60	Field Reversible	-	Integrated Solid	102 lb
UHNP315-IS01A	115 / 60	Field Reversible	Pump Included	Integrated Solid	107 lb

### Accessories

Model	Description	Finish	Shipping Weight
ULANUGGETCLEAN	Nugget Ice Cleaner (Single 8 oz. bottle)	N/A	1 lb
ULANUGGETFILTER	Replacement Water Filter (3 Class Nugget Ice)	N/A	2 lb
ULAWATERHOOKUP	Braided Water Supply Line Kit	N/A	2 lb

### Dimensions

#### Front

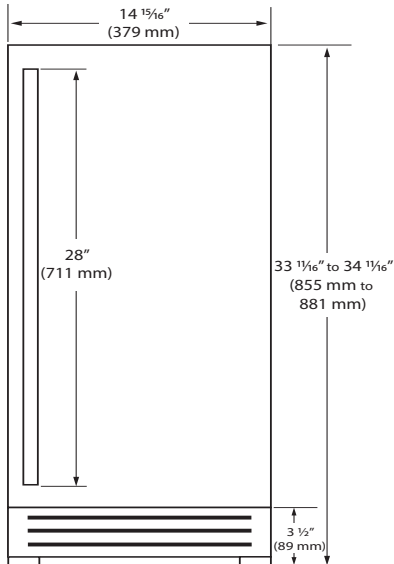

#### Side

\*Add 1/2" for Integrated models with 3/4" integrated panel installed.

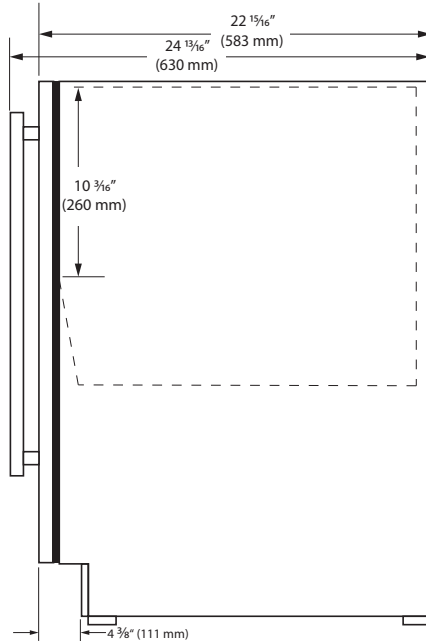

#### Top

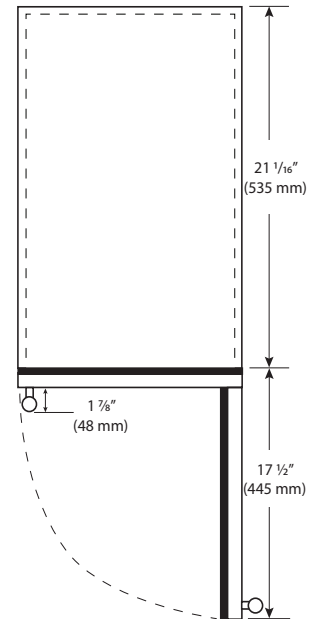

### Specifications

Model	HNB315
Amps: Running	3
Dimensions: Product Depth*	22 15/16" / 583 mm
Dimensions: Product Height	33 11/16" / 855 mm
Dimensions: Product Width	14 15/16" / 379 mm
ENERGY STAR	Yes
Ice Production Per Day	90 lb
Ice Storage	30 lb
Panel Height	30" / 762 mm
Panel Thickness	3/4" / 20 mm
Panel Type	Solid Panel
Panel Width	14 15/16" / 379 mm
Product Weight: Max	112 lb
Refrigerant Type	R600a
Sabbath (Star K Certified)	Yes

#### Back

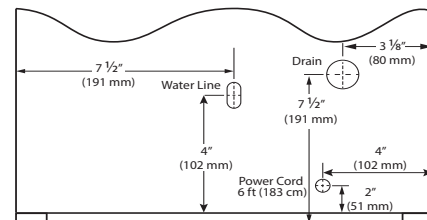

#### Cabinet Cut-Out

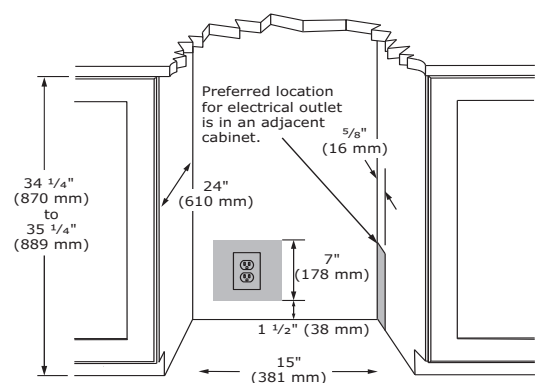

### Warranty

- 1 Year (parts & labor) / 5 year sealed system (parts)
- **2 Year (parts & labor) / 5 year sealed system (parts) upgrade at no cost with product registration**



See complete warranty for details

### Installation Notes

- No additional clearance is needed for ventilation
- Do not obstruct front grille air flow





Stainless Solid

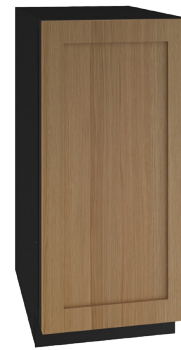

Integrated Solid

### Key Features

- **Industry Leading: Produces up to 90 lb of ice per day**
- **Industry Leading: Stores 30 lb of ice**
- Makes cylindrical compressed ice bits approx. 3/4" L x 1/2" H
- Eco friendly - most efficient type of specialty ice
- Digital touch pad control with blue LED display
- Indicator alert notifies user when cleaning is needed
- Soft close door with articulating hinge
- Bright white LED lighting
- White interior
- Stainless steel handle (7/8" diameter)
- Easiest nugget ice machine cleaning process in the industry
- Integrated model requires 3/4" custom door panel and handle (not supplied by U-Line)
- Field reversible door is shipped right-hand hinged
- Built-in or freestanding
- Four adjustable leveling legs
- Factory installed drain pump model recommended if a gravity drain is not accessible

### Model Details

Model	Voltage/Hz	Door Swing	Pump	Finish	Shipping Weight
UHNB115-SS01A	115 / 60	Field Reversible	-	Stainless Solid	101 lb
UHN115-SS01A	115 / 60	Field Reversible	Pump Included	Stainless Solid	106 lb
UHNB115-IS01A	115 / 60	Field Reversible	-	Integrated Solid	96 lb
UHN115-IS01A	115 / 60	Field Reversible	Pump Included	Integrated Solid	100 lb

### Accessories

Model	Description	Finish	Shipping Weight
ULANUGGETCLEAN	Nugget Ice Cleaner (Single 8 oz. bottle)	N/A	1 lb
ULAWATERHOOKUP	Braided Water Supply Line Kit	N/A	2 lb

### Dimensions

#### Front

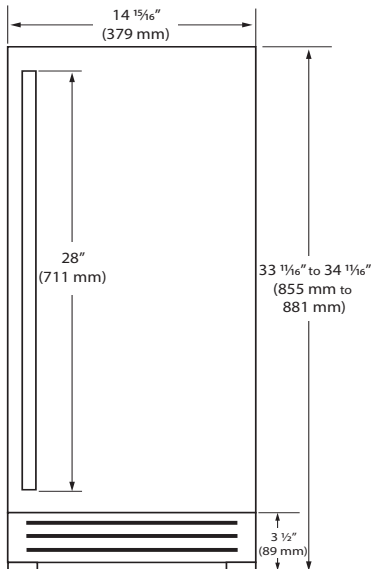

#### Side

\*Add 1/2" for Integrated models with 3/4" integrated panel installed.

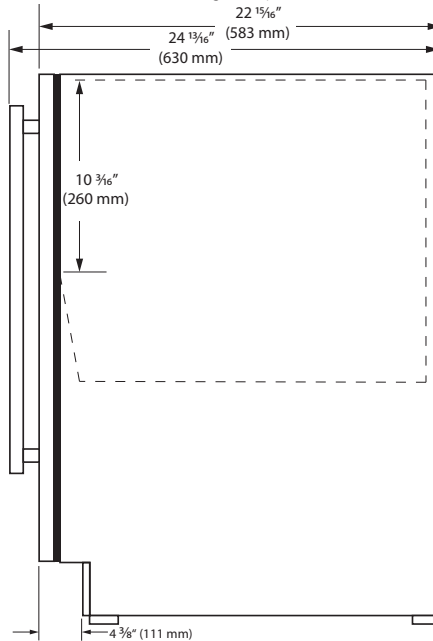

#### Top

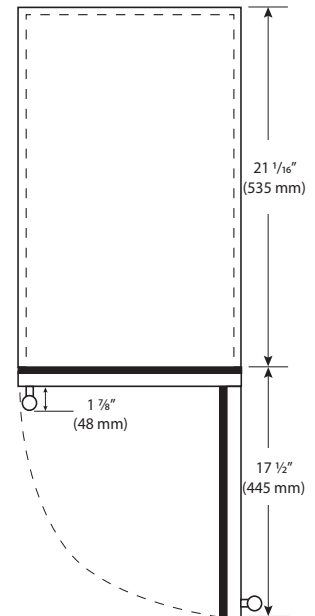

### Specifications

Model	HNB115
Amps: Running	3
Dimensions: Product Depth*	22 15/16" / 583 mm
Dimensions: Product Height	34 11/16" / 855 mm
Dimensions: Product Width	14 15/16" / 379 mm
ENERGY STAR	Yes
Ice Production Per Day	90 lb
Ice Storage	30 lb
Panel Height	30" / 762 mm
Panel Thickness	3/4" / 20 mm
Panel Type	Solid Panel
Panel Width	14 15/16" / 379 mm
Product Weight: Max	106 lb
Refrigerant Type	R134a
Sabbath (Star K Certified)	Yes

#### Back

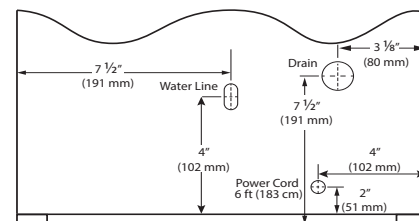

#### Cabinet Cut-Out

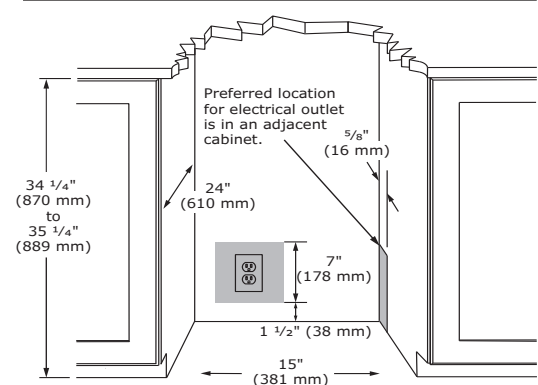

### Warranty

- 1 Year (parts & labor) / 5 year sealed system (parts)
- **2 Year (parts & labor) / 5 year sealed system (parts) upgrade at no cost with product registration**



See complete warranty for details

### Installation Notes

- No additional clearance is needed for ventilation
- Do not obstruct front grille air flow





Stainless Solid

### Key Features

- **Industry Exclusive: U-Choose™ feature offers five levels of ice density**
- **Industry Leading: Produces up to 90 lb of ice per day**
- **Industry Leading: Stores 30 lb of ice**
- Eco friendly - most efficient type of specialty ice
- Makes cylindrical compressed ice bits approx. 3/4" L x 1/2" H
- Digital touch pad control with blue LED display
- Indicator alert notifies user when cleaning is needed
- Bright white LED lighting
- White interior
- Stainless steel handle (7/8" diameter)
- Easiest nugget ice machine cleaning process in the industry
- Field reversible door is shipped right-hand hinged
- Built-in or freestanding
- Four adjustable leveling legs
- Factory installed drain pump model recommended if a gravity drain is not accessible

### Model Details

Model	Voltage/Hz	Door Swing	Pump	Finish	Shipping Weight
UANB115-SS01A	115 / 60	Field Reversible	-	Stainless Solid	90 lb
UANP115-SS01A	115 / 60	Field Reversible	Pump Included	Stainless Solid	95 lb

### Accessories

Model	Description	Finish	Shipping Weight
ULANUGGETCLEAN	Nugget Ice Cleaner (Single 8 oz. bottle)	N/A	1 lb
ULAWATERHOOKUP	Braided Water Supply Line Kit	N/A	2 lb



### Dimensions

#### Front

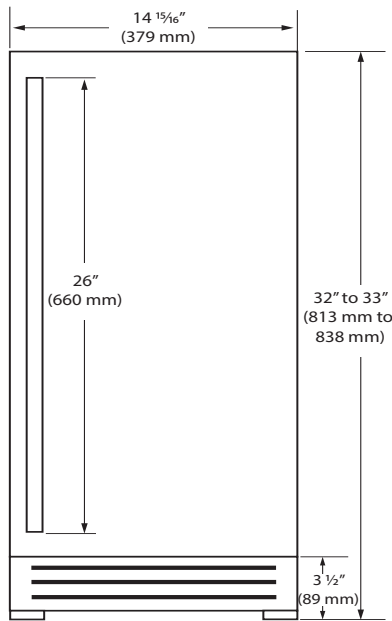

#### Side

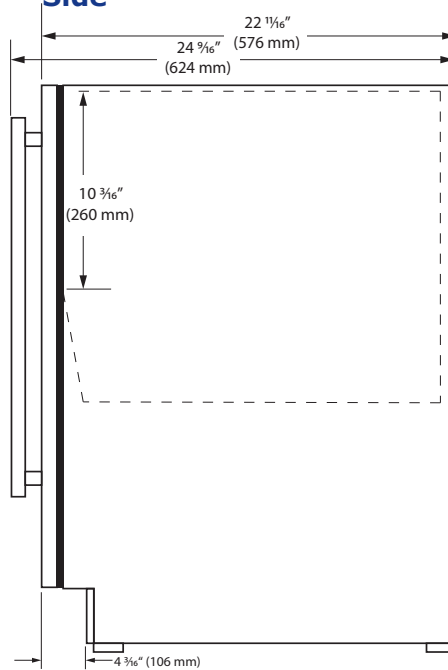

#### Top

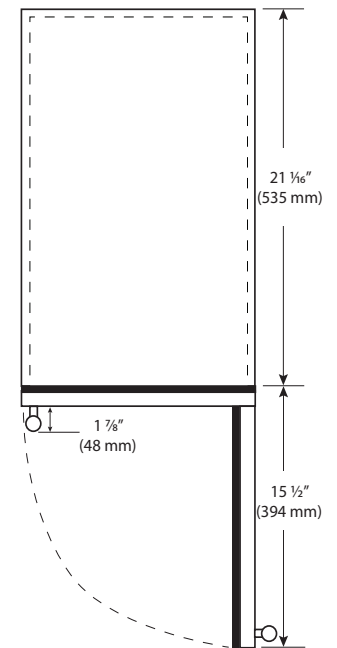

### Specifications

Model	ANB115
Amps: Running	3
Dimensions: Product Depth	22 1/16" / 576 mm
Dimensions: Product Height	32" / 813 mm
Dimensions: Product Width	14 15/16" / 379 mm
ENERGY STAR	Yes
Ice Production Per Day	90 lb
Ice Storage	30 lb
Product Weight: Max	95 lb
Refrigerant Type	R600a
Sabbath (Star K Certified)	Yes

### Back

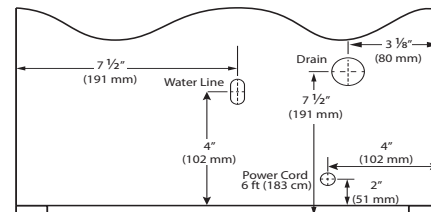

### Cabinet Cut-Out

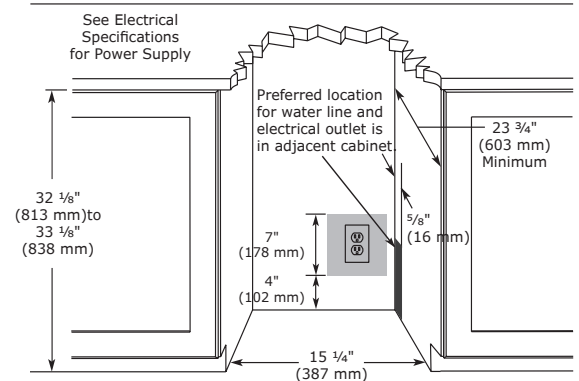

### Warranty

- 1 Year (parts & labor) / 5 year sealed system (parts)
- **2 Year (parts & labor) / 5 year sealed system (parts) upgrade at no cost with product registration**



See complete warranty for details

### Installation Notes

- 15" cutout width sufficient if door protrudes beyond adjacent cabinetry
- No additional clearance is needed for ventilation
- Do not obstruct front grille air flow





Stainless Solid

### Key Features

- **Industry Leading: Produces up to 90 lb of ice per day**
- **Industry Leading: Stores 30 lb of ice**
- Eco friendly - most efficient type of specialty ice
- Makes cylindrical compressed ice bits approx. 3/4" L x 1/2" H
- Digital touch pad control with blue LED display
- Indicator alert notifies user when cleaning is needed
- Bright white LED lighting
- White interior
- Stainless steel cabinet, toe-kick, and full-wrap door
- Stainless steel handle (7/8" diameter)
- Easiest nugget ice machine cleaning process in the industry
- Field reversible door is shipped right-hand hinged
- Built-in or freestanding
- Four adjustable leveling legs
- Factory installed drain pump model recommended if a gravity drain is not accessible

### Model Details

Model	Voltage/Hz	Door Swing	Pump	Finish	Shipping Weight
UONB115-SS01A	115 / 60	Field Reversible	-	Stainless Solid	96 lb
UONP115-SS01A	115 / 60	Field Reversible	Pump Included	Stainless Solid	101 lb

### Accessories

Model	Description	Finish	Shipping Weight
ULANUGGETCLEAN	Nugget Ice Cleaner (Single 8 oz. bottle)	N/A	1 lb
ULAWATERHOOKUP	Braided Water Supply Line Kit	N/A	2 lb

### Dimensions

#### Front

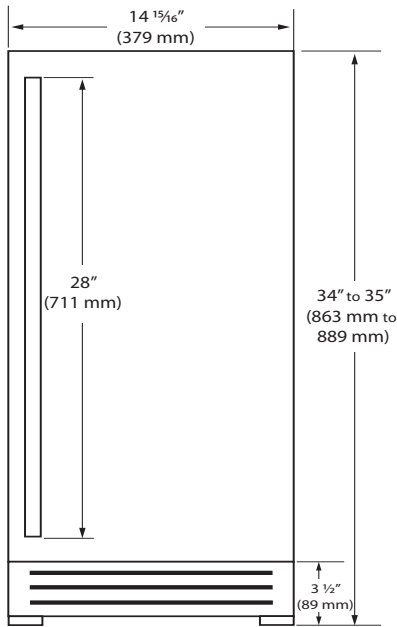

#### Side

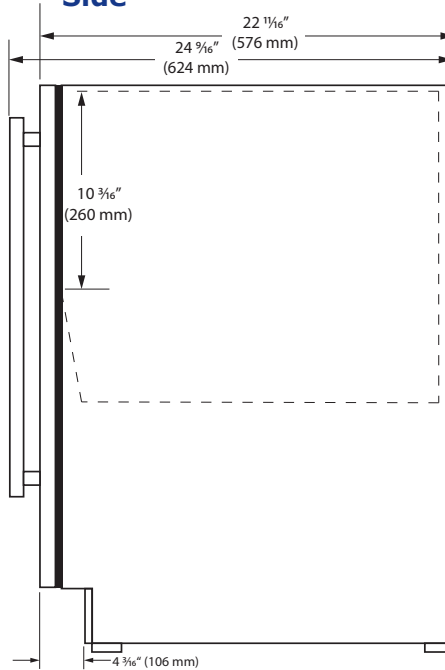

#### Top

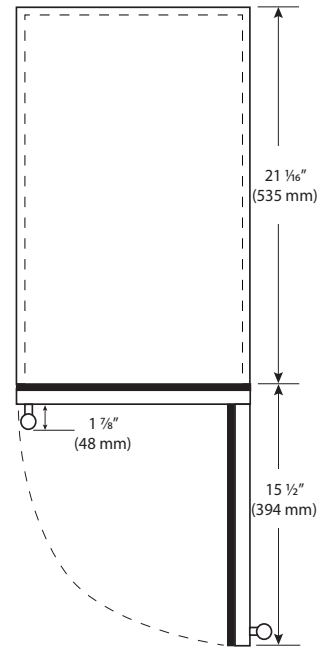

### Specifications

Model	ONB115
Amps: Running	3
Dimensions: Product Depth	22 11/16" / 576 mm
Dimensions: Product Height	34" / 863 mm
Dimensions: Product Width	14 15/16" / 379 mm
ENERGY STAR	Yes
Ice Production Per Day	90 lb
Ice Storage	30 lb
Product Weight: Max	101 lb
Refrigerant Type	R134a
Sabbath (Star K Certified)	Yes

### Back

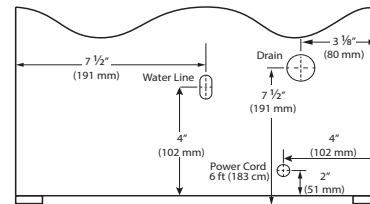

### Cabinet Cut-Out

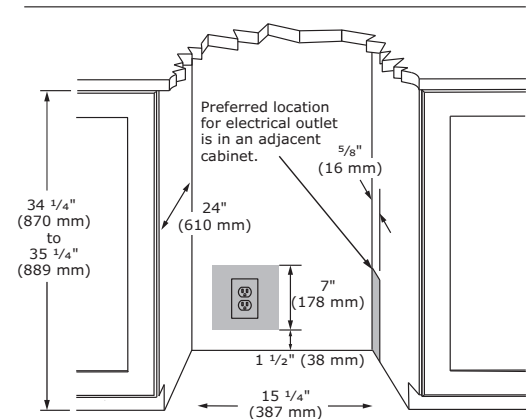

### Warranty

- 1 Year (parts & labor) / 5 year sealed system (parts)
- **2 Year (parts & labor) / 5 year sealed system (parts) upgrade at no cost with product registration**



See complete warranty for details

### Installation Notes

- 15" cutout width sufficient if door protrudes beyond adjacent cabinetry
- No additional clearance is needed for ventilation
- Do not obstruct front grille air flow





U-LINE

RIGHT PRODUCT. RIGHT PLACE. RIGHT TEMPERATURE. SINCE 1962.



Beverage Centers • Wine Captain® Models • Ice Machines • Refrigerators • Freezers

u-line.com • +1.414.354.0300 • sales@u-line.com •    